

Outback Accessories Australia

Part No. XRNAV –XROX Steel Tube Bar

Nissan Navara D22 07/2001 on

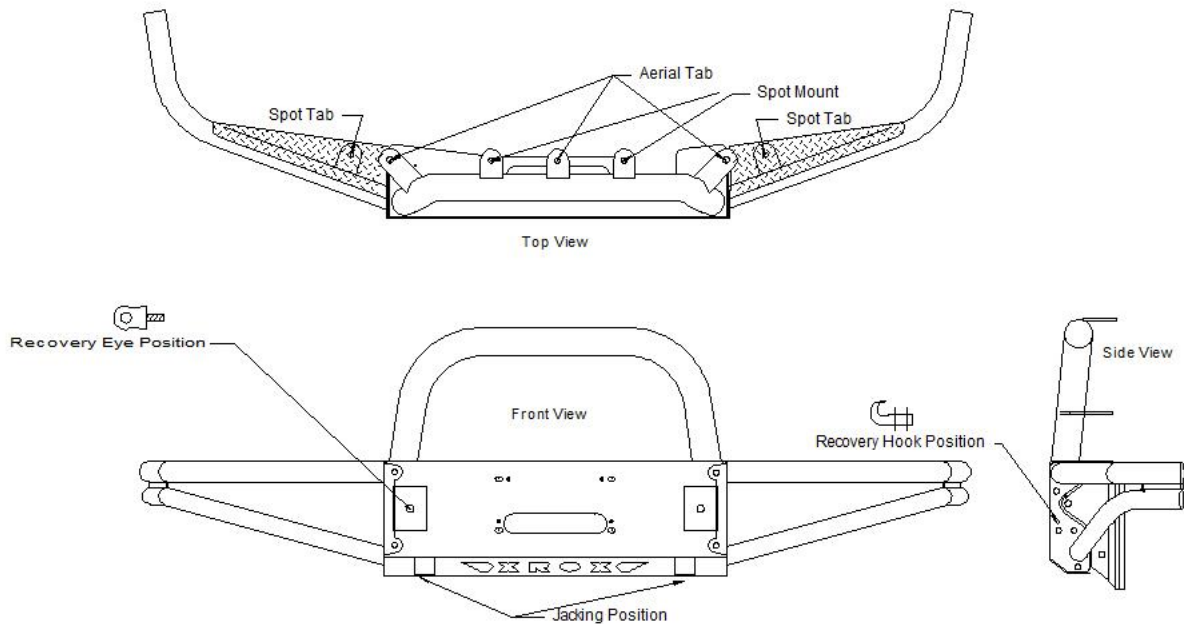

This bar has detachable side wings that can be replaced if damaged; plus 6 spot tab, 3 aerial tabs, 2 jacking positions, 2 recovery eye and 2 hook locations. (Recovery eyes & hooks are not provided in this kit). The bar has been developed to accept up to a 15,000Lb. Warn low mount winch. (*Note: 50mm Lift mounts are available mount ID: XN5*).

This bar & fitting kit is certified as being compatible with the Air Bag system of this vehicle. This sticker is to be attached to the up side of the centre section of the bumper pressing. The vehicle make and model need to be marked on the sticker with a ball point pen after it has been attached to the bar.

Fitting Instructions

1. Remove bumper and bumper mounts from vehicle.
2. Fit both bull bar mounts to the vehicle chassis using 4) 10x30 1.25 bolts. A 10mm hole will need to be drilled through the top of each chassis rail with 2) M10 x 110 bolts fitted. Mark & drill hole from top before fitting.

If fitting 50mm Lift Mounts: Fasten the rear bracket hole to the tow hook using a 12x40 bolt, 50x5 washer, 12mm washer and spring washer. An additional 50x5 washer may be needed as a spacer and is provided in the kit.

3. Press the tube inserts into the ends of the wings. Use sikaflex or similar sealant to create watertight seal, and assemble the side tube wings to the bar centre using 8) M10 bolts, washers, s/washers, nuts, 4) M12 bolts, washers, s/washers and nuts. 4) M12 button head allen bolts are used to bolt the front of the side wing to the centre.
4. Fit the assembled tube bar to the mounts and align the bar to the vehicle. Use 8) M12 bolts, washers, s/washers and nuts. Level Xrox bar and tighten all bolts except the bottom two, which are used to fasten the bash plate.
5. Bash Plate: The front of the bash plate fastens to the existing bottom bolts which fasten the Xrox bar to the mounts Once front is fitted, fasten the rear of the bash plate using 2) 12x30 1.25 bolts, washers & spring washers. Tighten all bolts.

If fitting 50mm lift mounts: Fasten the front of the bash plate to mounts using the dedicated holes provided using 2) 12x35 bolts, washers and spring washers and 2) 12 x 3 washers as spacers.

6. Fit the number plate with the existing screws.
7. Fit the Air conditioning Protector using 4) M6 mudguard washer bolts. The R/H side fastens through the existing air conditioning bracket into captive nuts. 2) 8mm holes will need to be drilled for the L/H side. Level, and tighten all bolts.

If a winch is being fitted an optional hinged number plate holder part No. SP27 is available. This is an additional cost.

(Note: 50mm Lift mounts and extended front protection guard are available).

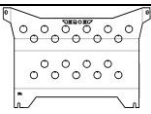
Qty.	Description	Qty.	Description
1	XROX Bar Centre (C01)	16	12mm Nuts
1	D22 XROX Side Wing R/H (29)	18	12mm Spring Washers
1	D22 XROX Side Wing L/H (30)	34	12mm Flat Washers
2	Navara D22 Mounts (XN)	2	10x110 Bolts
1	Navara D22 Bash plate (XN) 	8	10x25 Bolts
1	Navara D22 Aircon Protector (XN)	4	10x30 1.25 Bolts
1	Air Bag Protection Sticker	10	10mm Nuts
2	Plastic Tube Inserts 48mm (ID 42mm)	24	10mm Flat Washers
2	Plastic Tube Inserts 42mm (ID 36mm)	14	10mm Spring Washers
12	12x35 Bolts	4	M6 Mudguard Washer Bolts
4	12x40 Button Head Allan Bolts	2	M6 Washered Nuts
2	12x30 1.25 Bolts		Fitting instructions

*****Extra parts required for 50mm Lift Kit*****

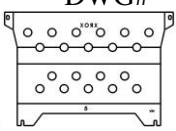
Qty.	Description	Qty.	Description
4	50x5 Round Washers	2	12x30 Bolts
10	12 x 3mm flat washers	4	12mm nuts
2	12x40 Bolts	2	12mm spring washers
2	D22 XROX Mounts (id: XN5 DWG# XRNAV-7)		
1	D22 XROX Front Protection Guard (id:NV5 DWG# XRNAV-10) 		

Kit Packed by:	Checked By:	Date:
----------------	-------------	-------