



[www.hsputelids.com](http://www.hsputelids.com)

**1300 441 498**

Part No: T18

Fitting Time: 45mins



**New-Gen Mitsubishi MV Triton**

**HSP TAIL LOCK**  

---

**Fitting instructions**

# BOX CONTENTS

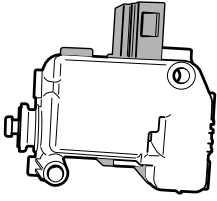

ACT-01

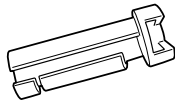

ACT-01-CAM

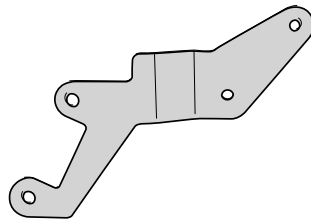

T18-A



T18-B

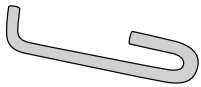

T18-C

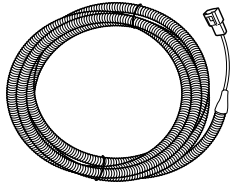

CL-LOOM-LONG

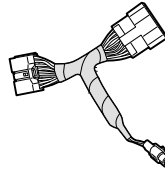

T-PATCH

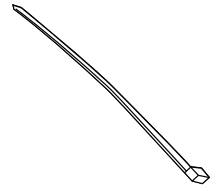

CABLE TIE  
Qty x 24



36  
QTY - 2

## SECTION ONE - WIRING INSTALLATION

1

Remove tailgate access panel.

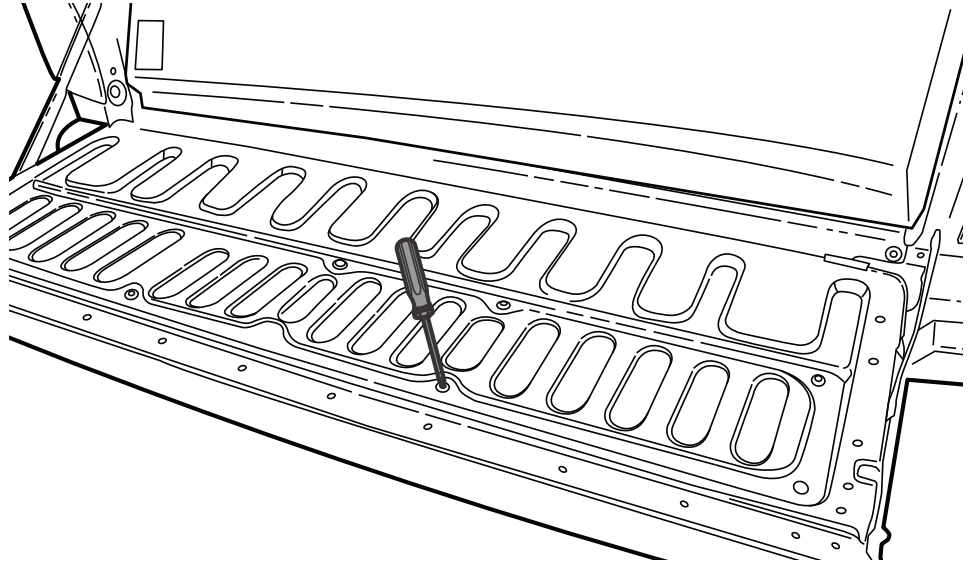

2

Run wiring ( CL-Loom-Long) from inside of tailgate ( leaving 200mm overhang to the location indicated ) towards passenger side B pillar.

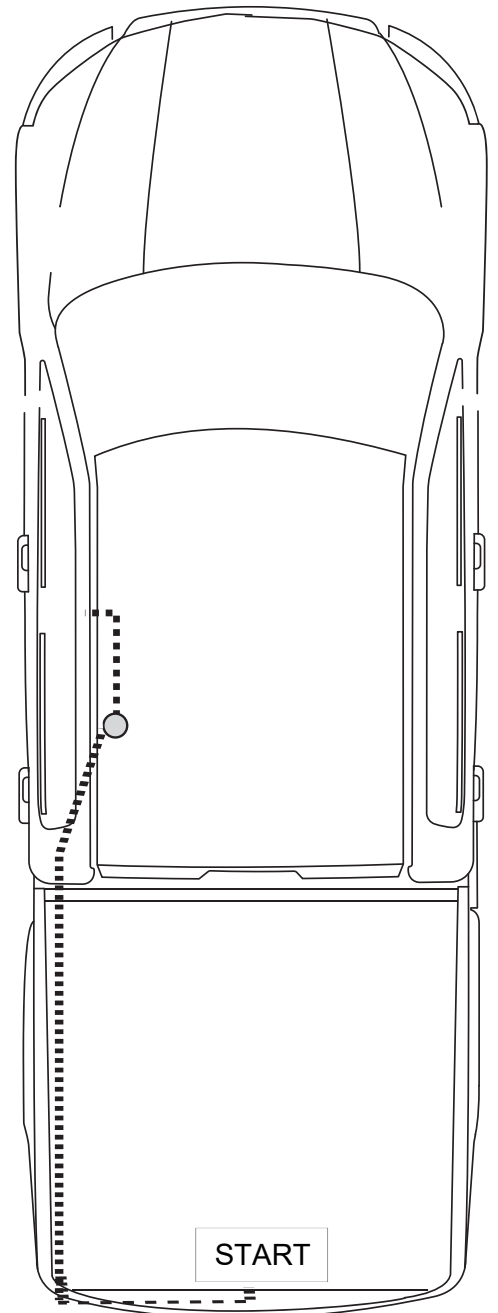
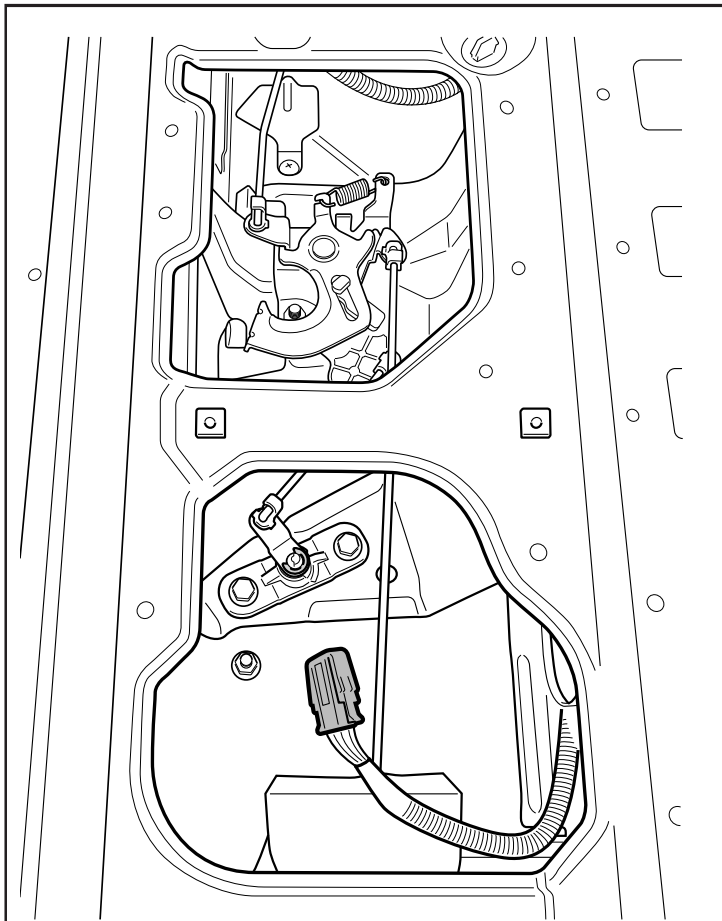

3

- a. Remove the harness and rubber grommet from the indicated location of the passenger side B pillar.
- b. Unplug the male and female connectors from the harness.
- c. Connect the T-patch to both the male and female connectors of the harness.
- d. Keep the harness outside for the time being.

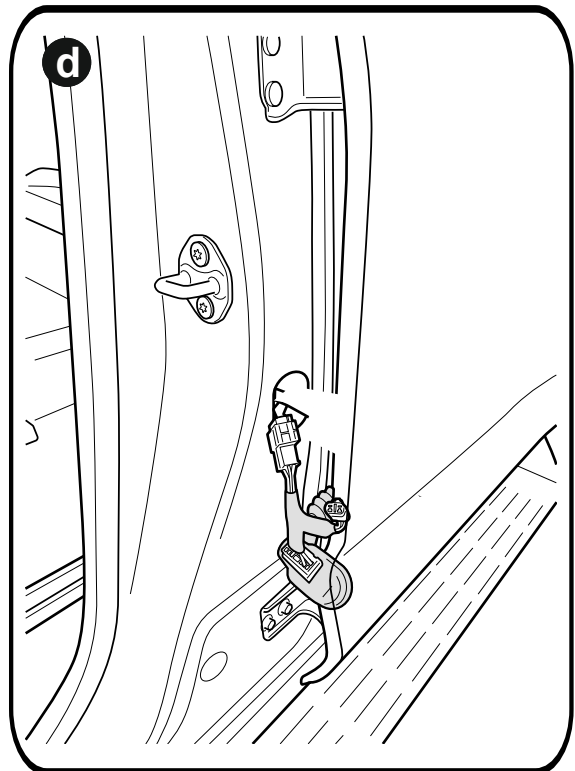
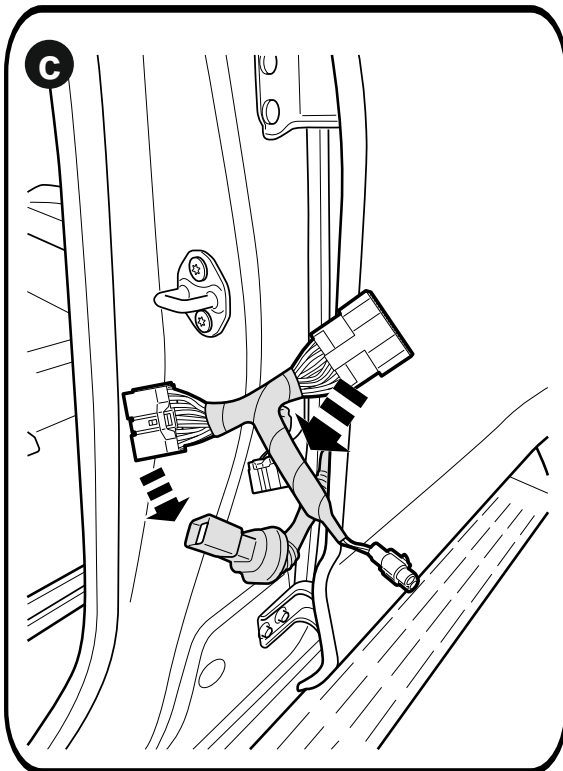
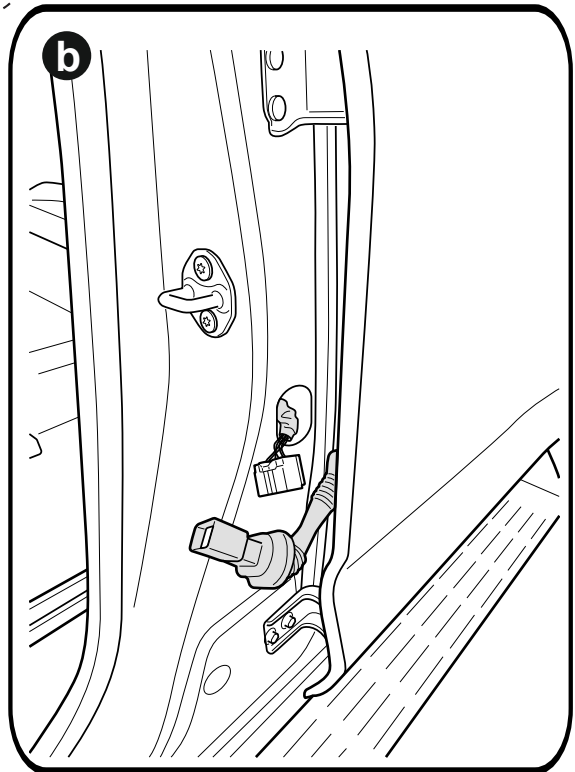
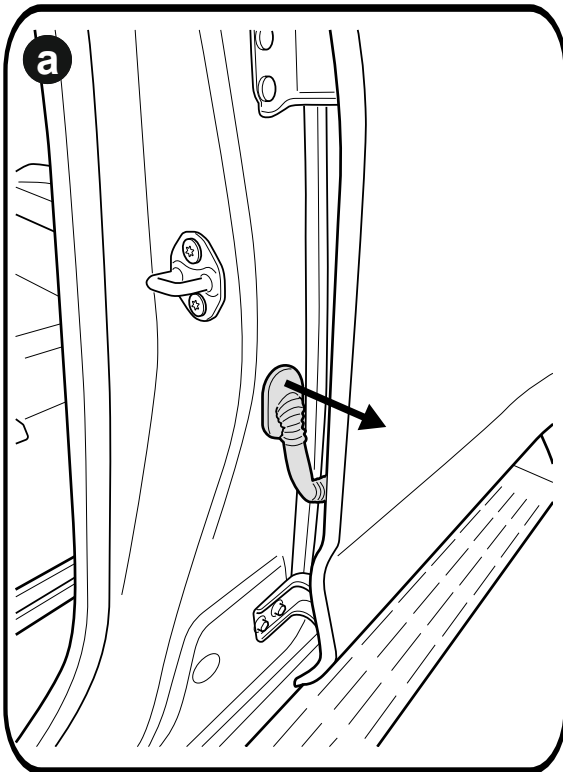
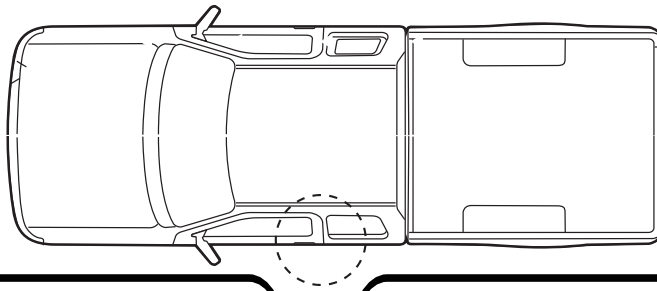

4 With care remove the front passenger side scuff panel.

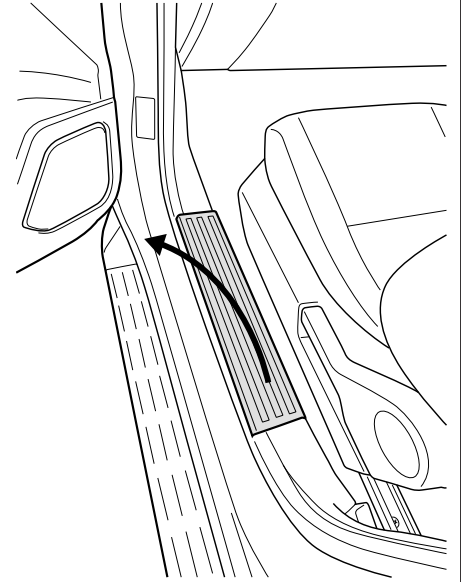

5 With care remove the rear passenger side scuff panel.

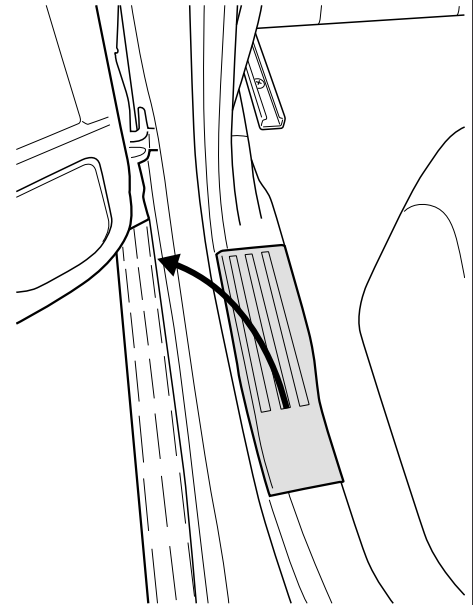

6 With care remove the passenger side B pillar lower and upper trims as indicated.

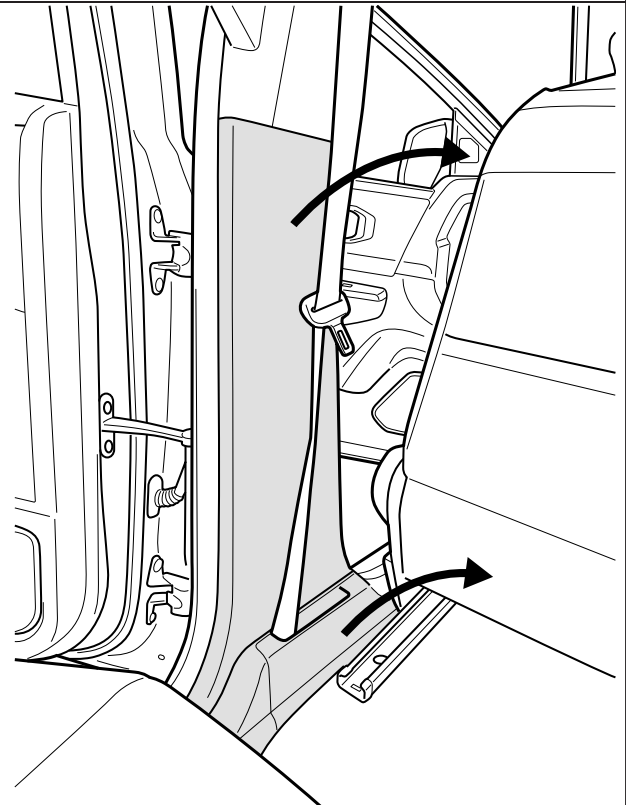

- 7 Locate the large floor grommet under the carpet of the passenger side rear foot well. Remove and retain grommet.

VEHICLE CABIN, UNDER CARPET VIEW

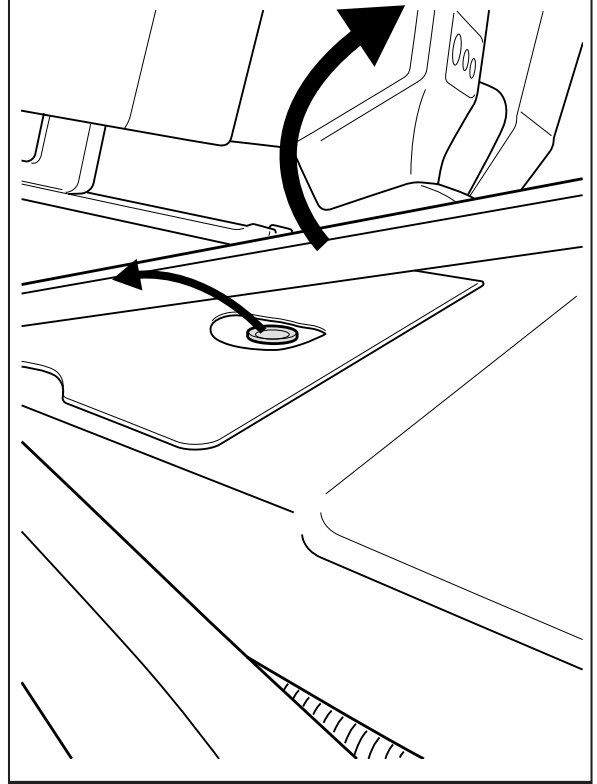

VEHICLE UNDERSIDE VIEW

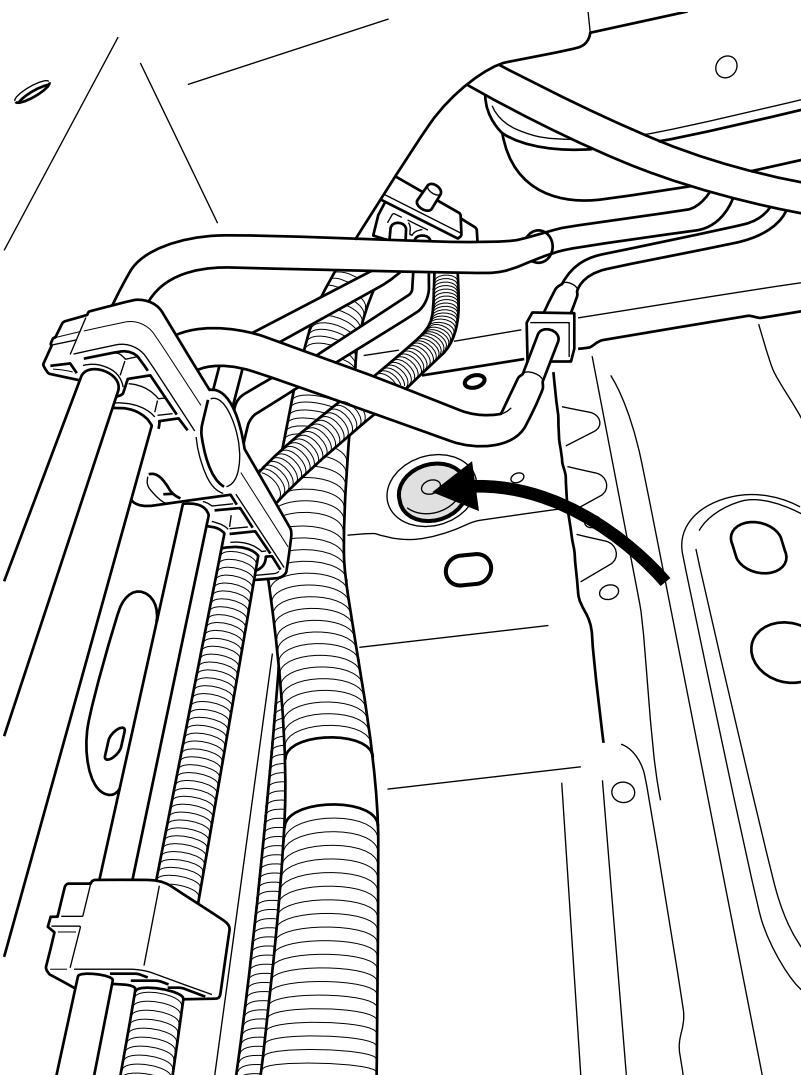

8 Feed CL-Loom-Long through the underside hole and into the cabin.

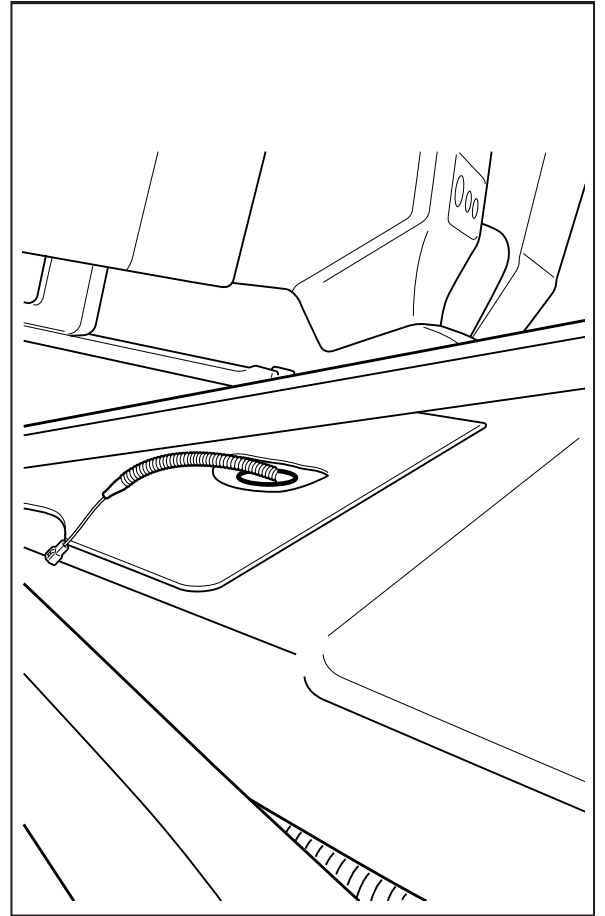
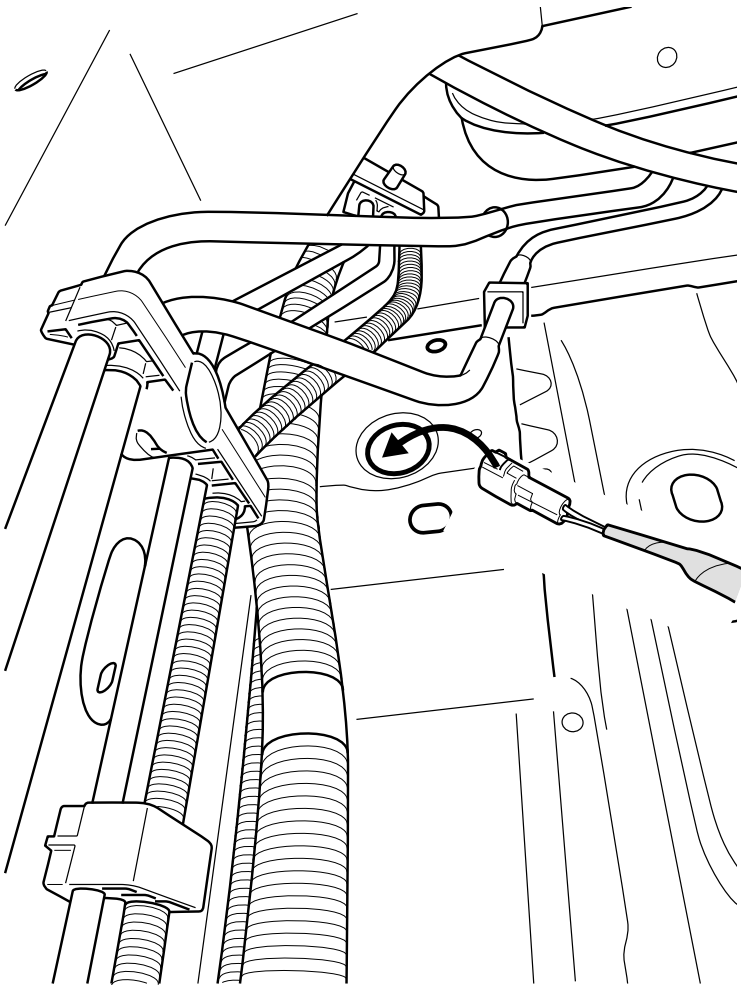

9 Make a small incision to the retained grommet & run the loom through it.

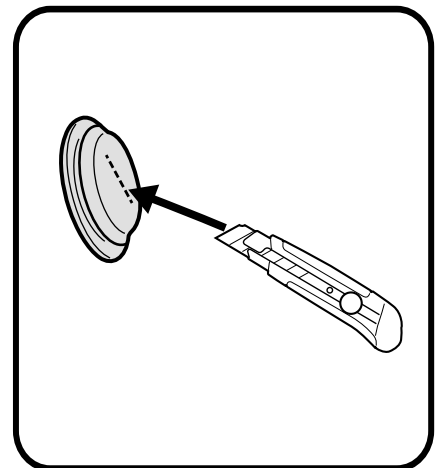
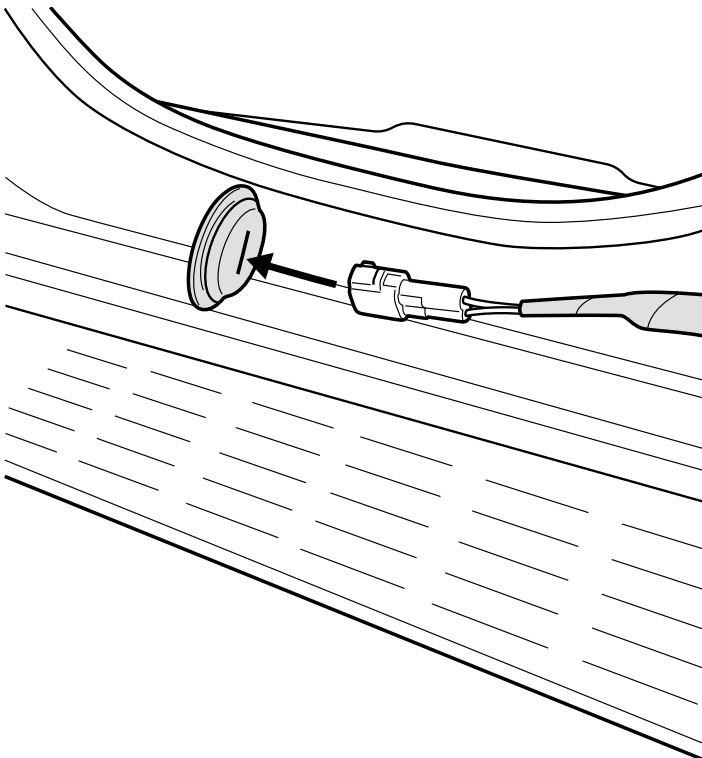

- 10 Un-clip the white indicated harness clip from the B pillar.

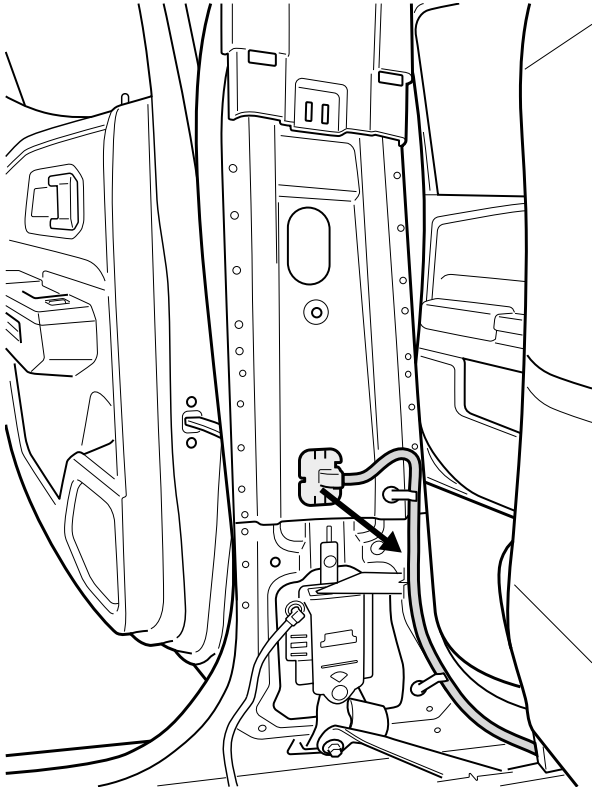

Feed CI-Loom-Long through the exposed cavity.

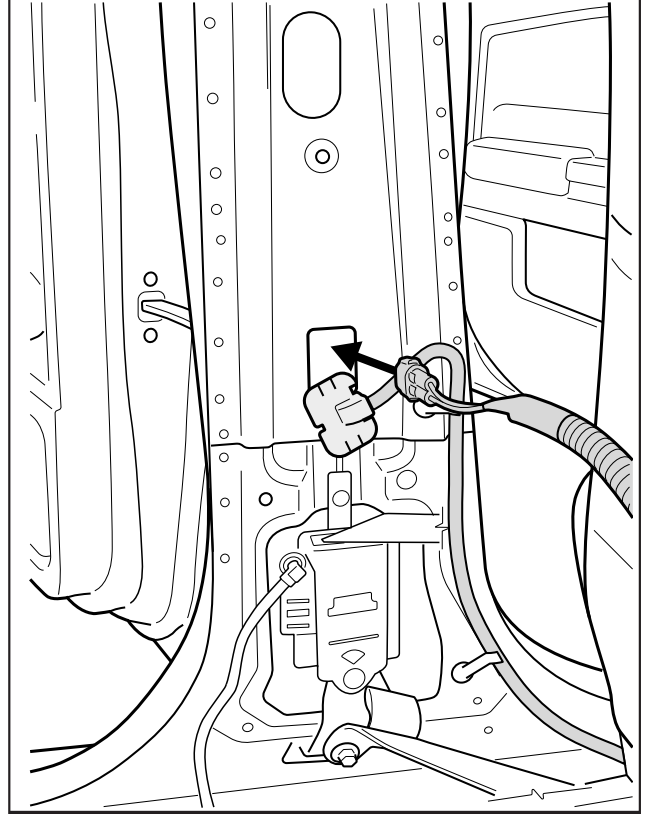

- 11 Feed CL-Loom-Long through to the outside exposed cavity of the B pillar.  
Now connect CL-Loom-Long to T - Patch.

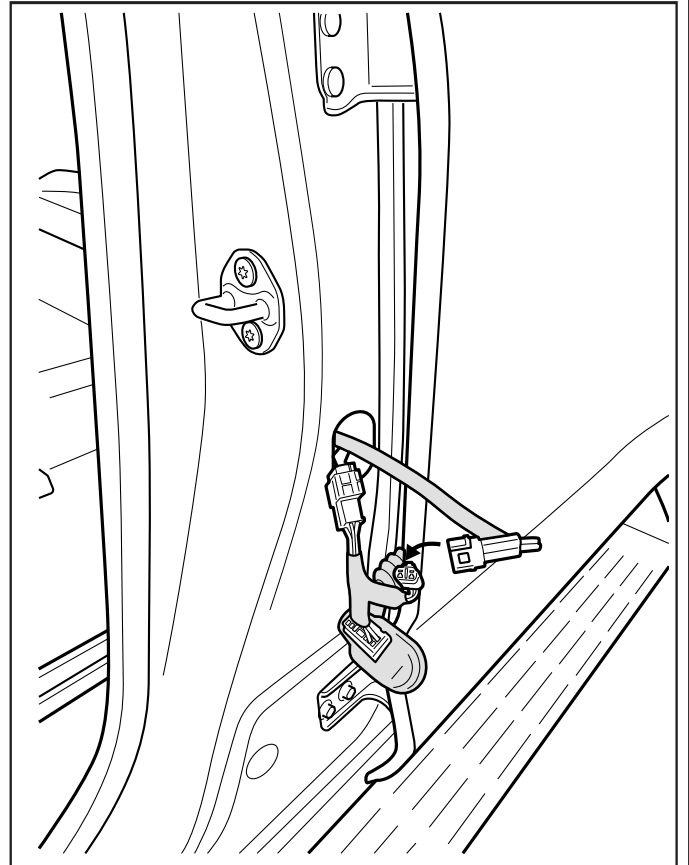
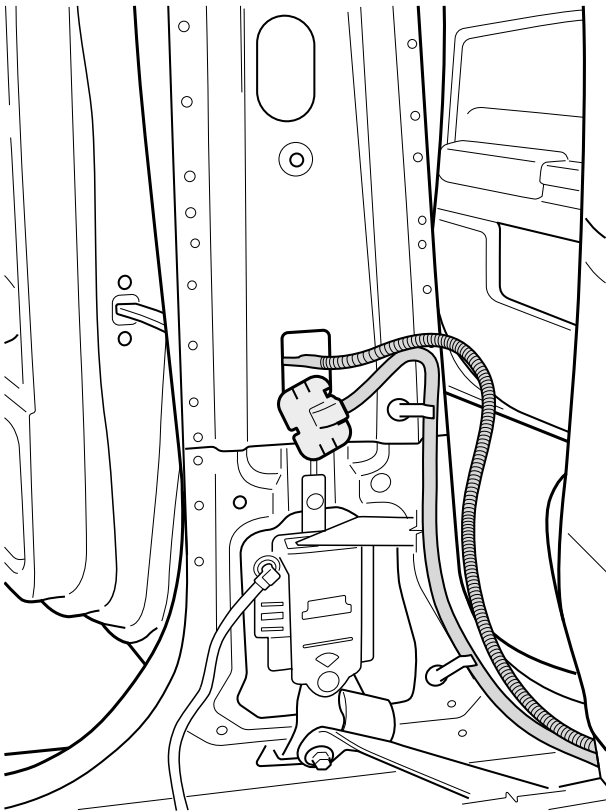



- 12 Feed harness back into cavity and re-fit the harness grommet to the pillar.

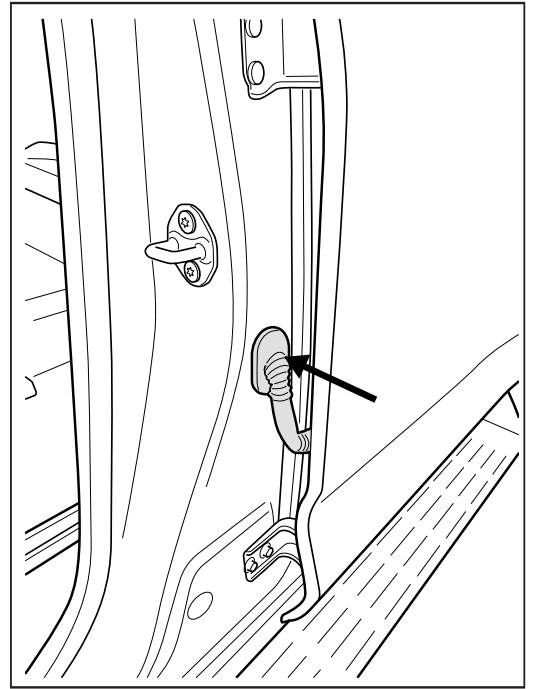
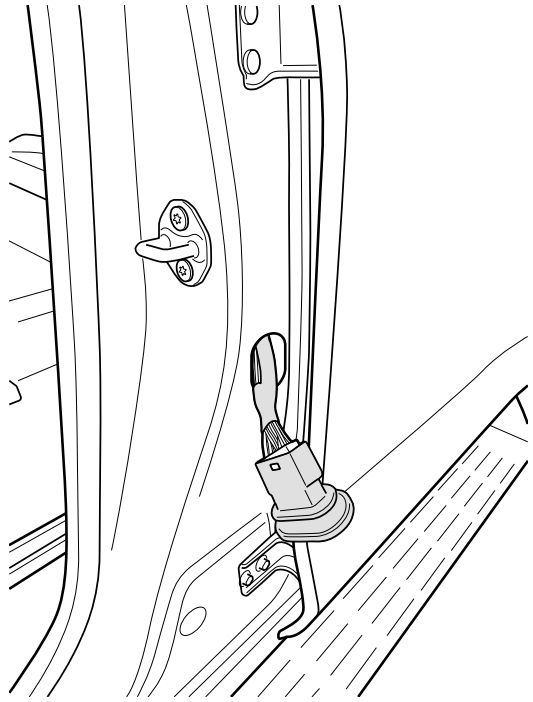

- 13 Align CL-Loom-Long's conduit to indent on the pillar. Now with care push harness plug back in to place.

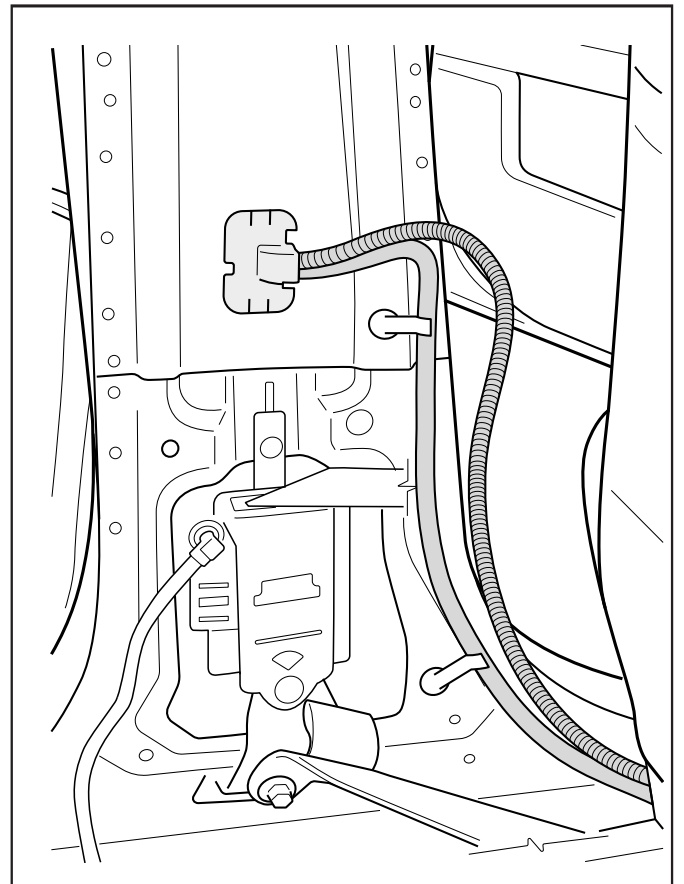
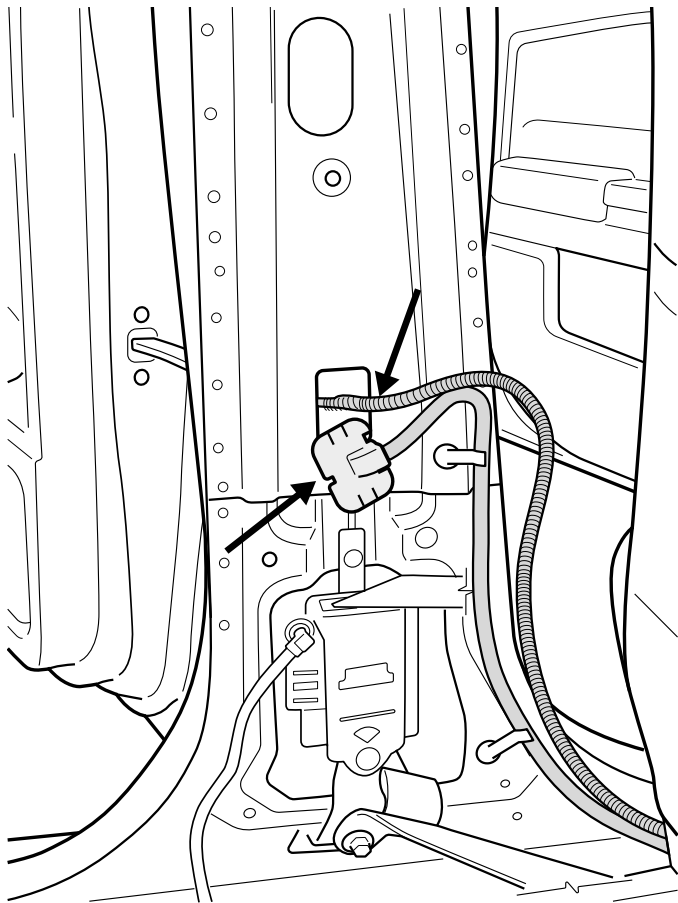

- 14 Cable tie the loom to the factory harness as indicated.

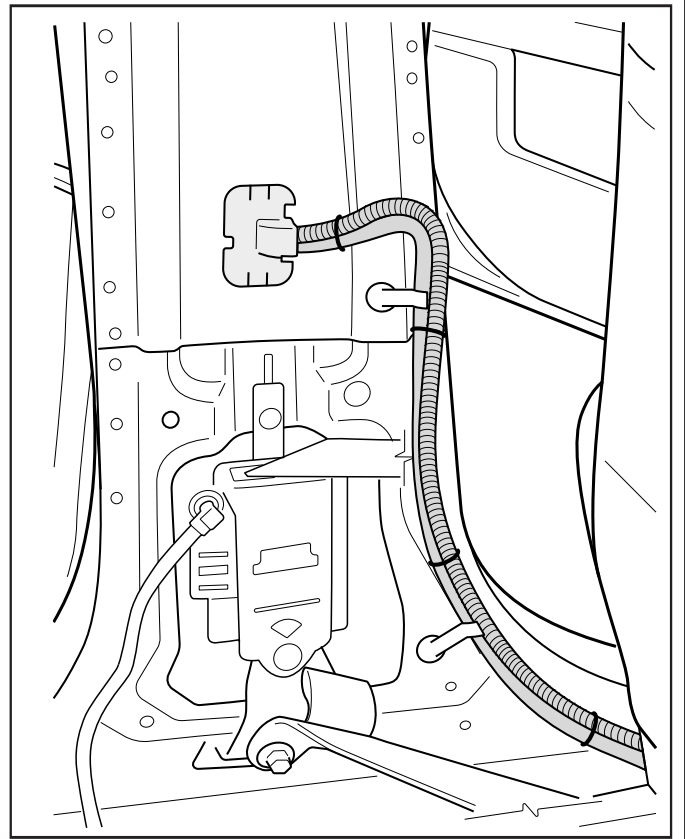

- 15 Fit the grommet back into its location. Then apply adequate amount of black sealant to the grommet's slit from top and bottom in order to seal correctly. Zip tie any loose hang on the loom to the factory harness.

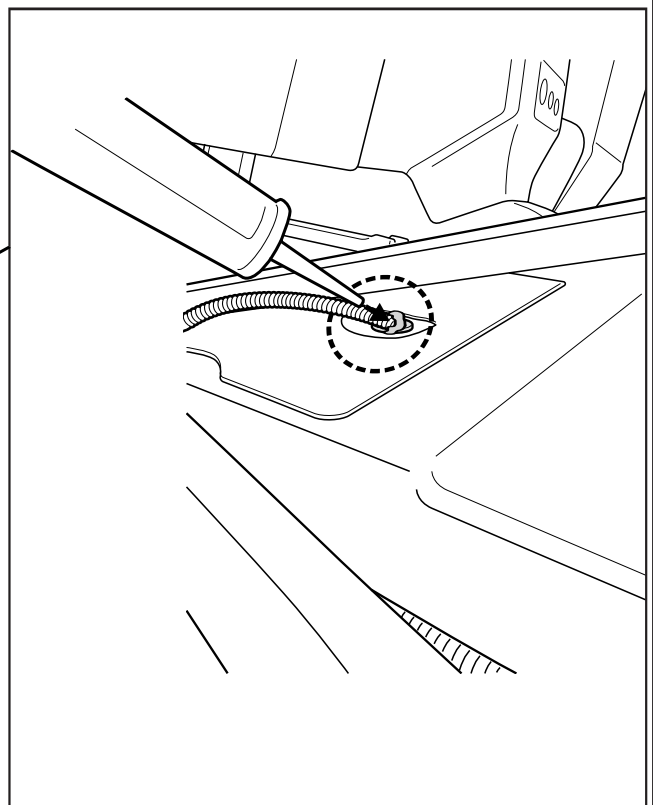
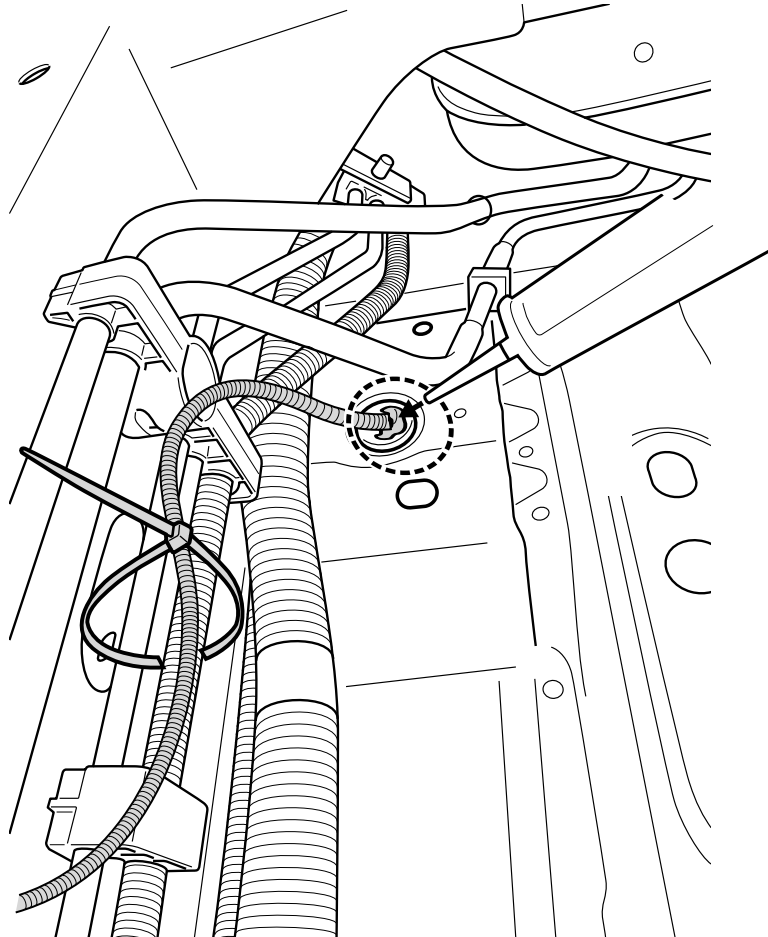

## SECTION TWO - LOCKING ASSEMBLY INSTALLATION

- 1
  - a. Un-hook the indicated rod from its clip and housing.
  - b. With care, remove the E clip from the indicated location and retain.

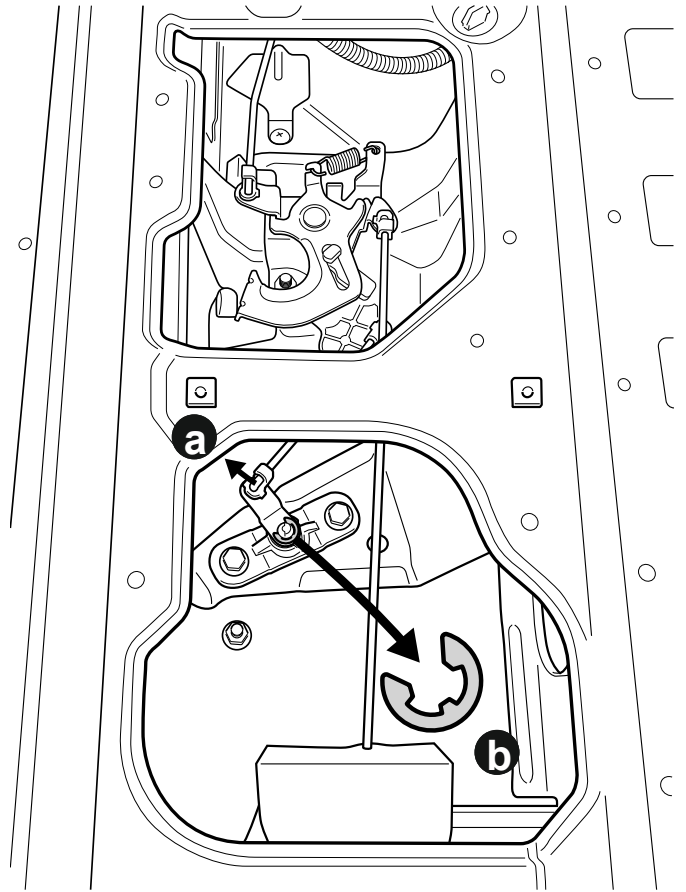

- 2
  - a. Remove indicated cam from its lock.
  - b. There will be a curved spring washer exposed after removal of the cam, do not remove and retain in its position i& orientation.

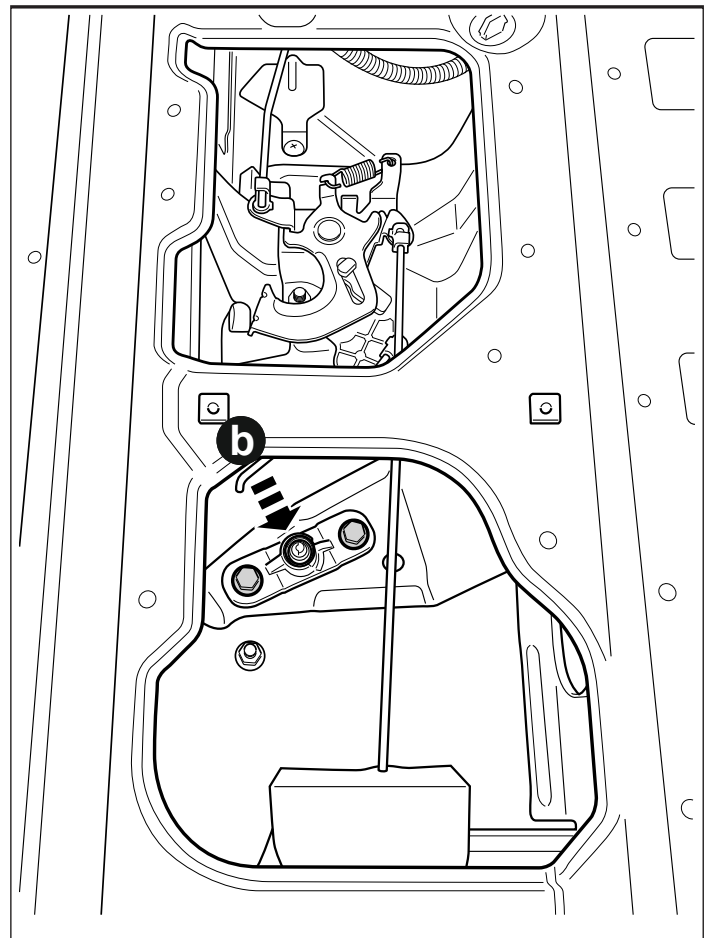
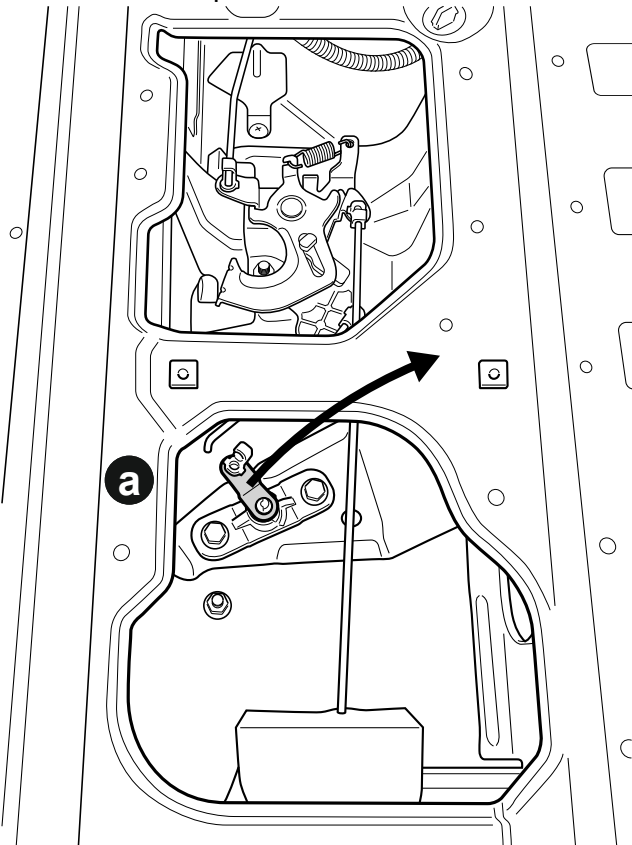

- 3 With care, remove and retain the rod clip from the factory cam.  
Discard the factory cam.

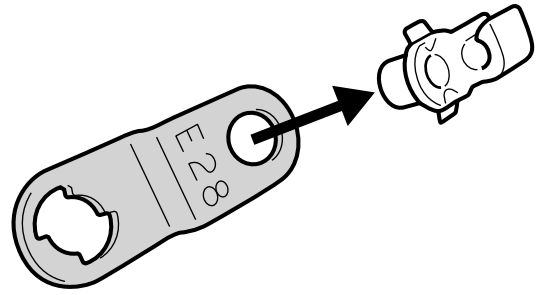

- 4 Fit rod clip to the indicated location of the supplied T18-B (cam bracket).

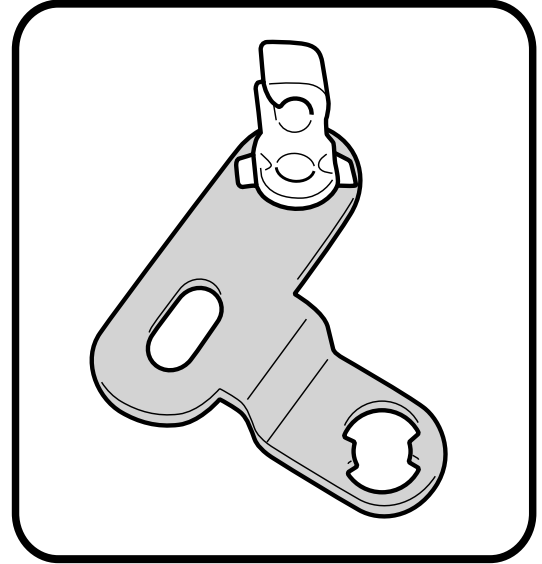
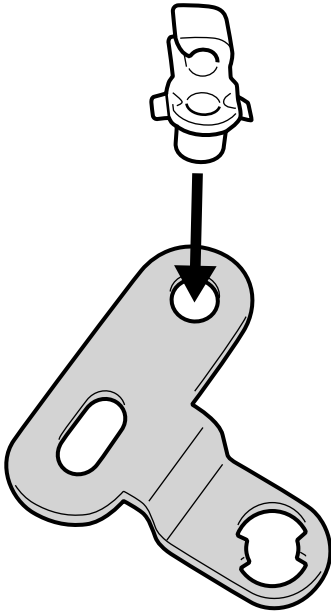

- 5 Unfasten the indicated bolts and retain.

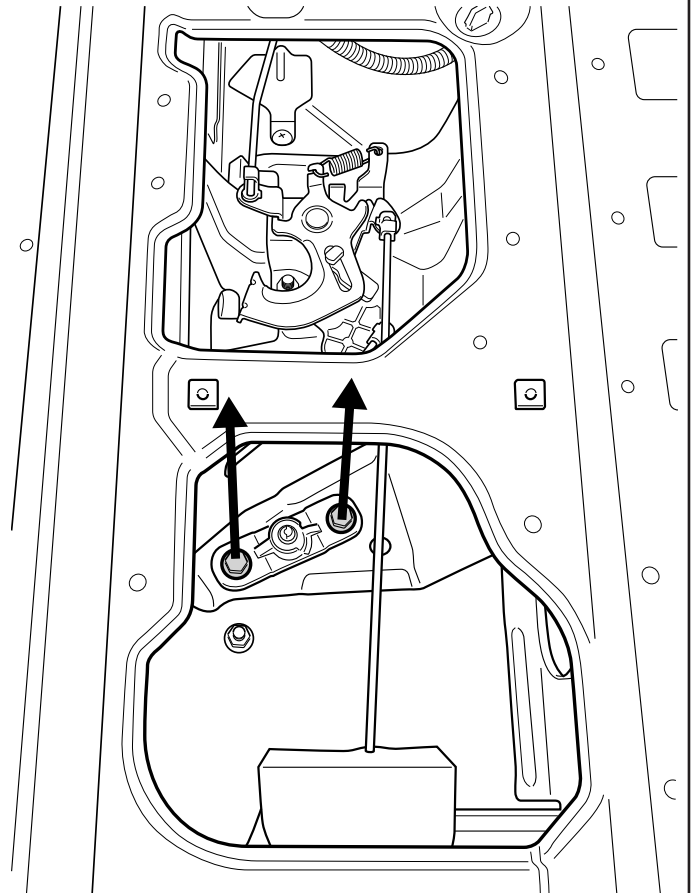

6

Using actuator screws (36) fit actuator to TailLock bracket ( T18-A) as shown.

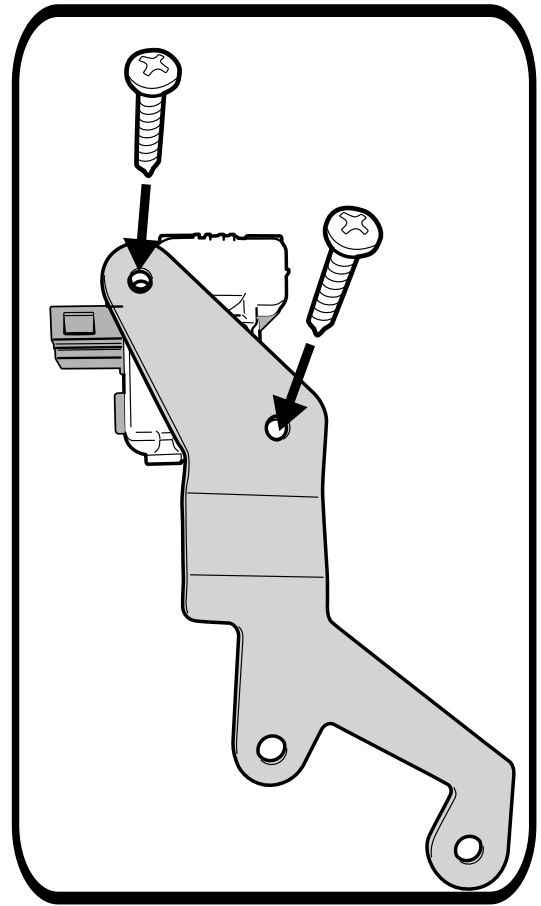
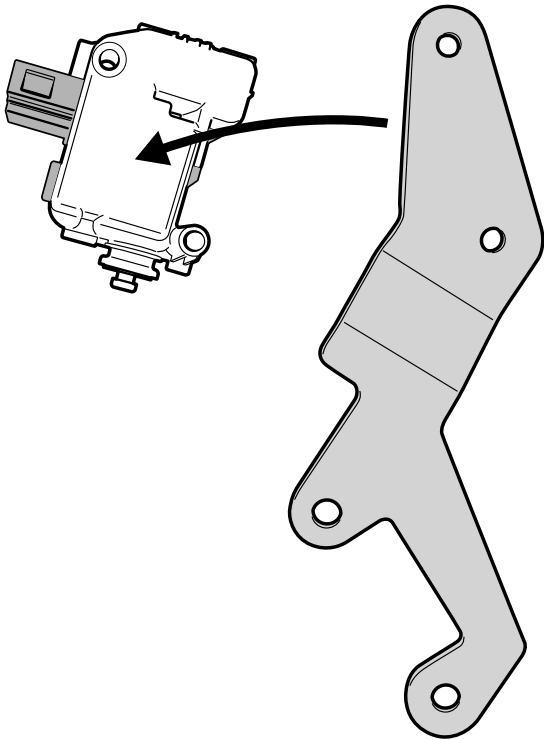

7

- a. Plug CL-Loom-Long to Actuator ( ACT-01).
- b. Align T18-A bracket to the indicated area.

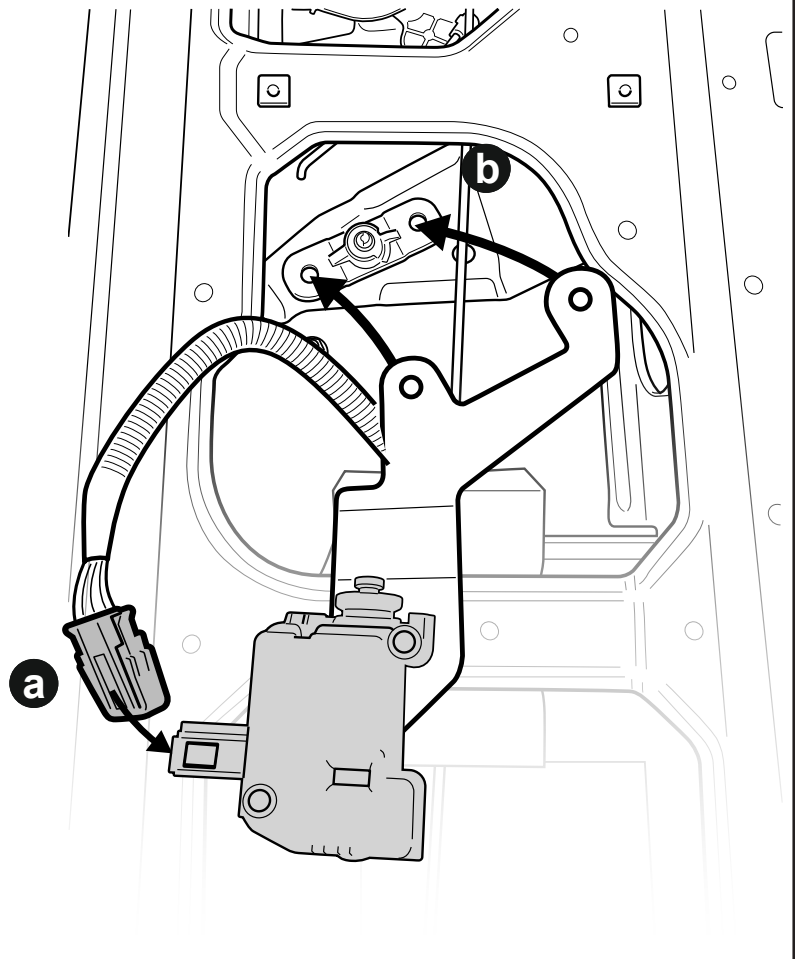

- 8 Fasten into position using retained factory bolts.  
**Note:** Refer to workshop manual for torque settings.

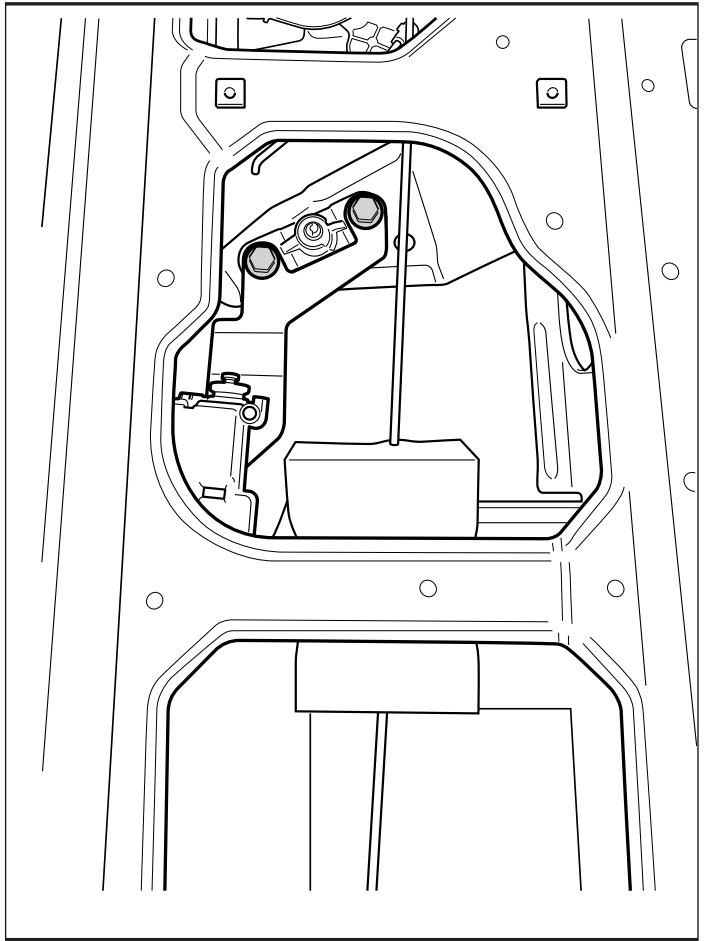

- 9 Load Rod (T18-C) into the actuator striker (ACT-01-CAM) as shown.

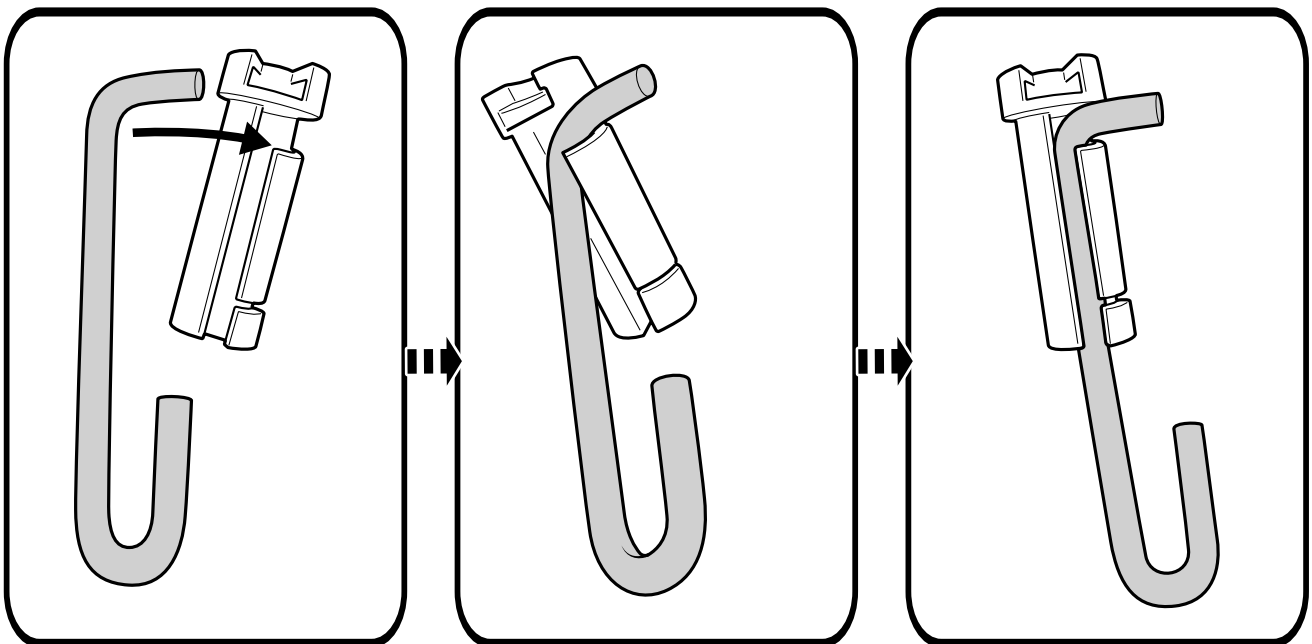

10 In the indicated orientation fit cam (T18-B) to the lock.

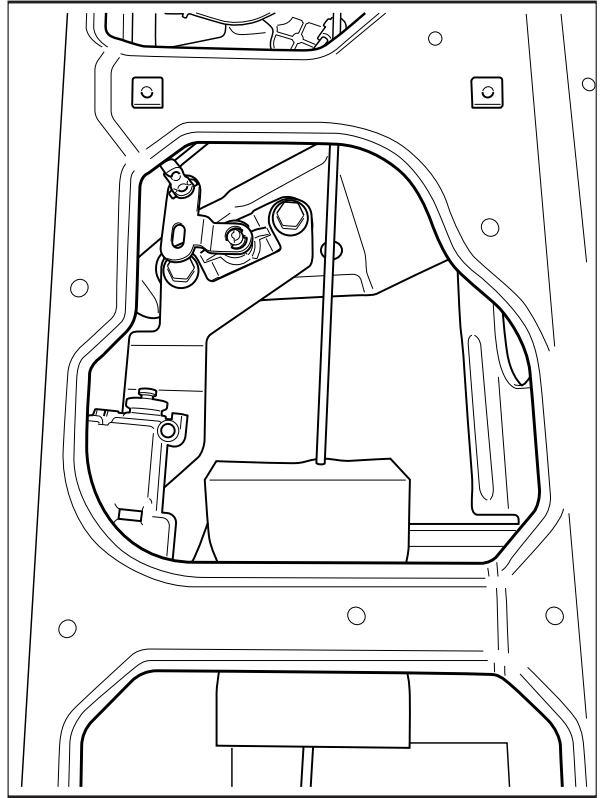
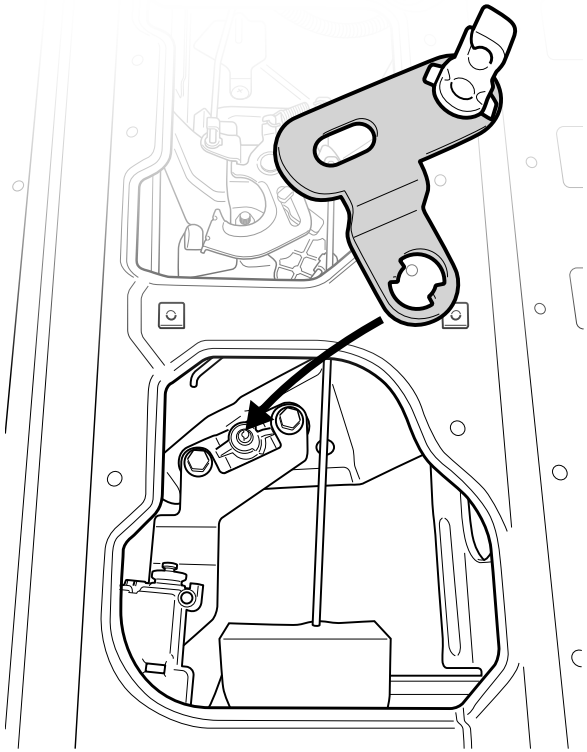

11 Use the retained E clip removed from original cam to secure the new cam in place.

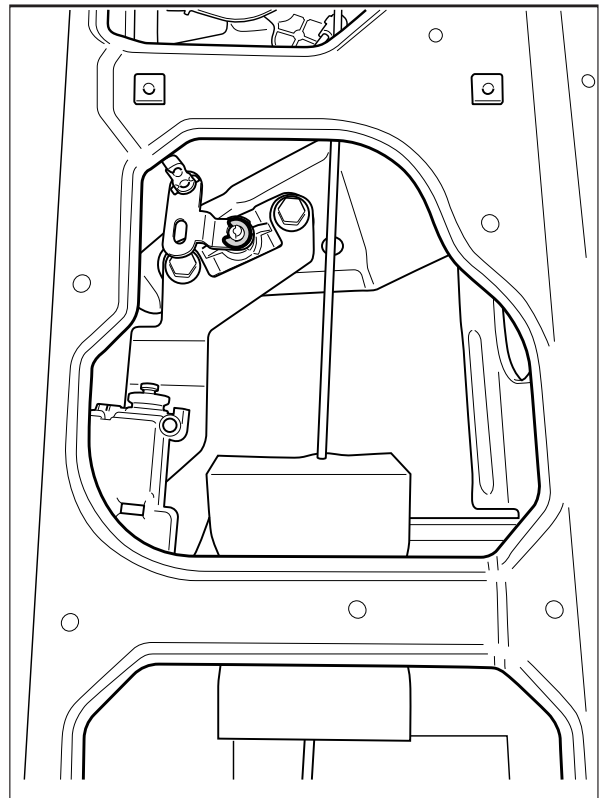
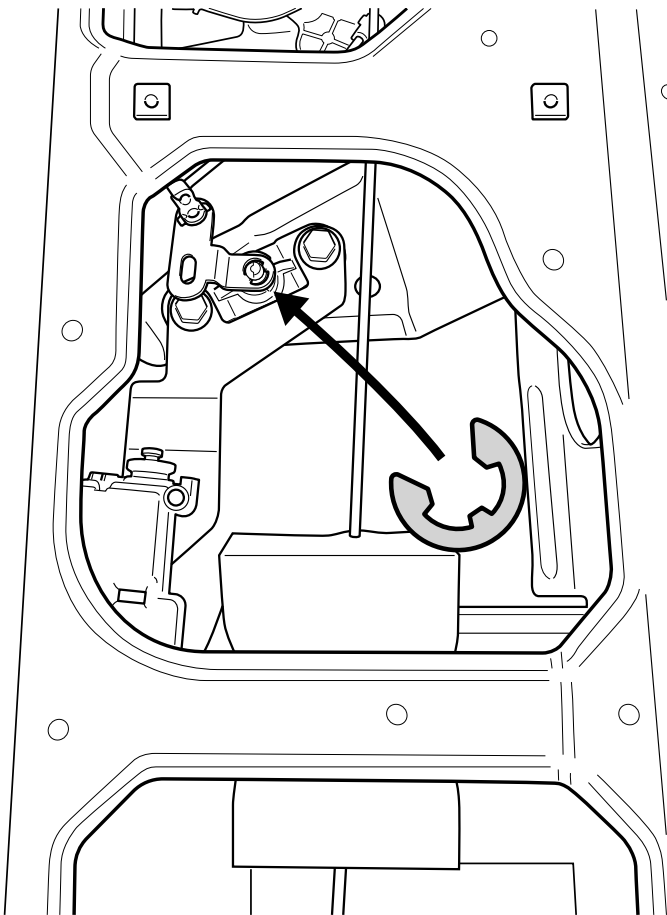

- 12 Align and insert indicated rod clip to the housing, and Secure the rod by rotating the rod clip.

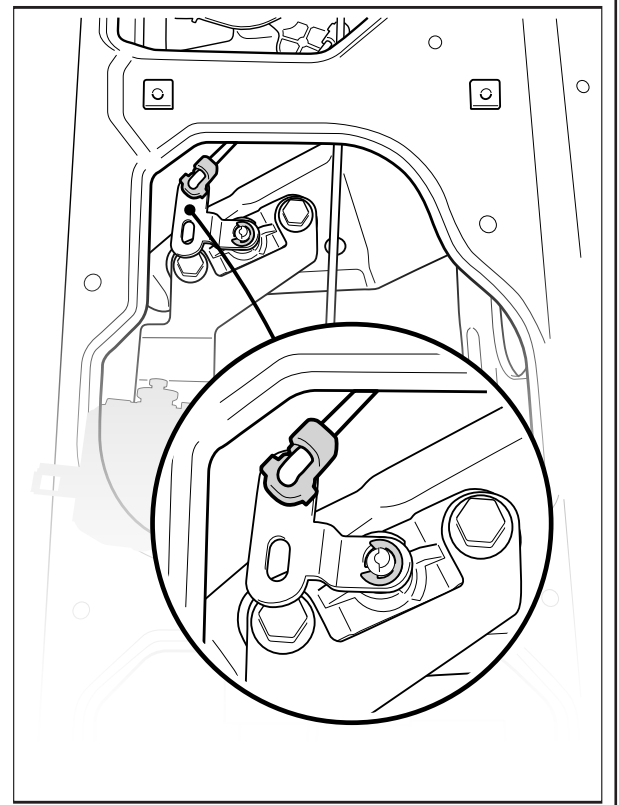
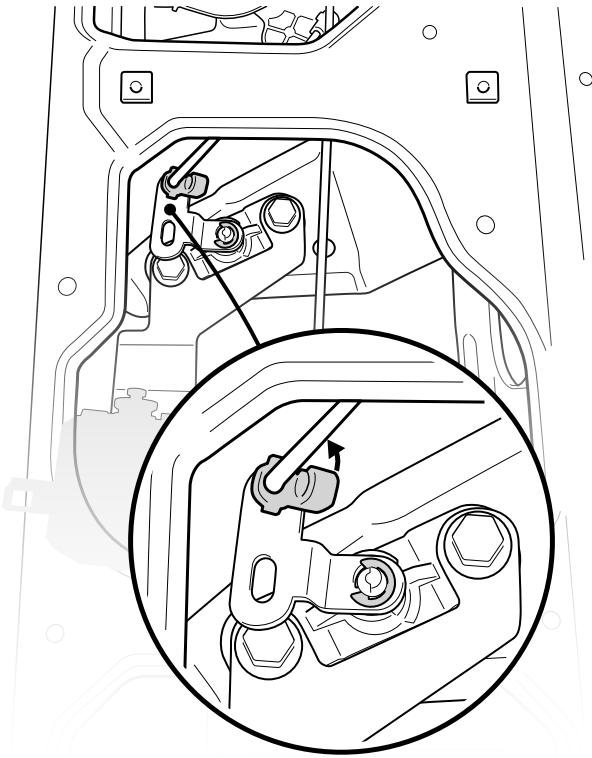

- 13
- Hook in the assembled Rod (T18-C) into the specified locations, following the displayed orientation.
  - As indicated, align assembled (T18-C and ACT-01-Cam) with the actuator.

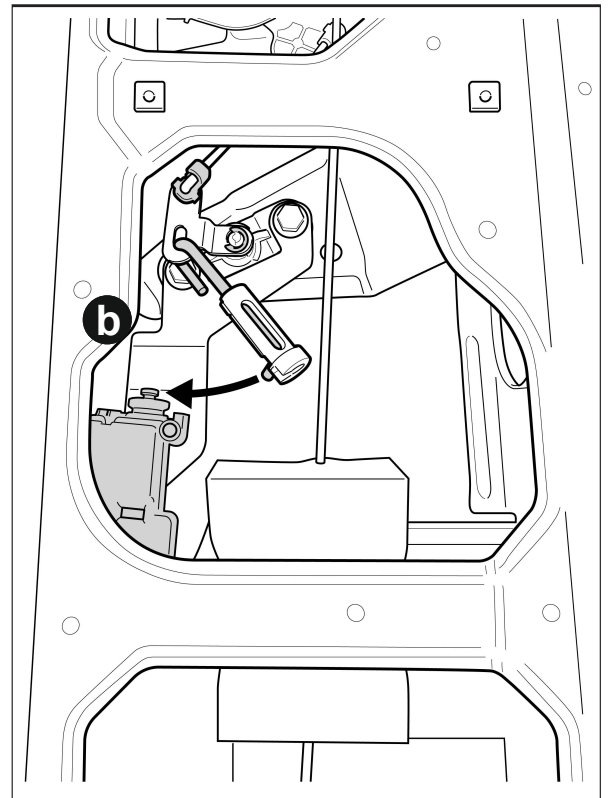
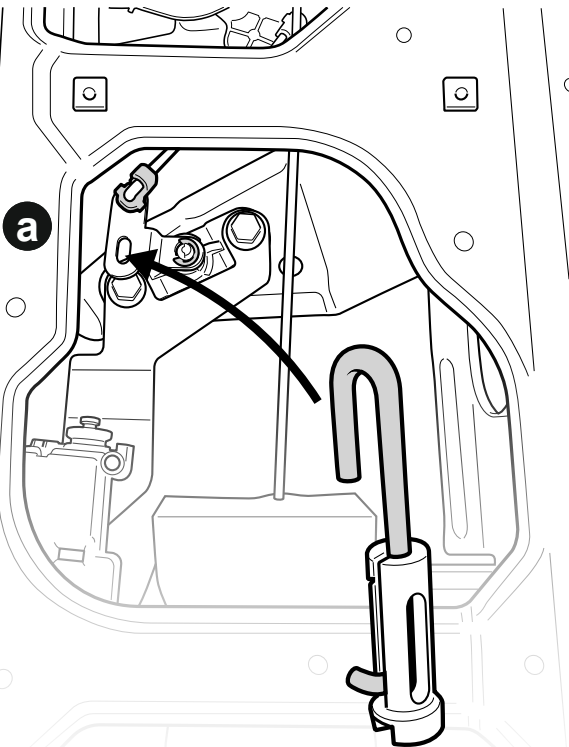



14

Push assembled (T18-C and ACT-01-Cam) on to the actuator till it clicks in to position.

**Note:** Little force will be required.

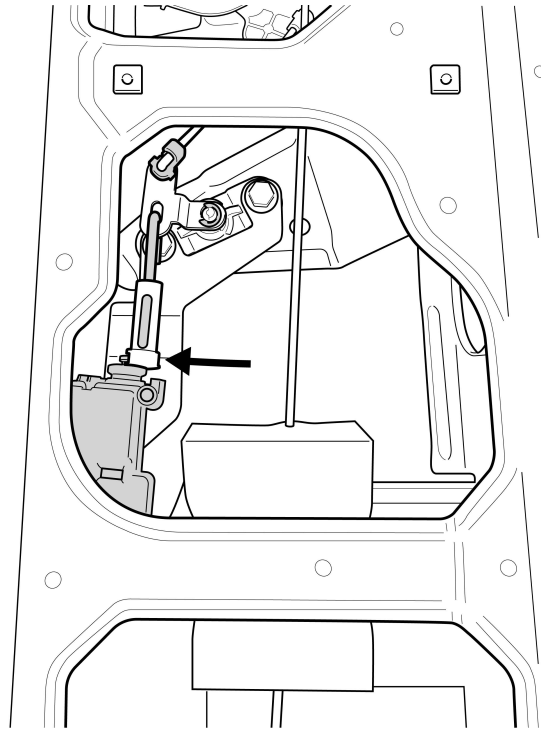
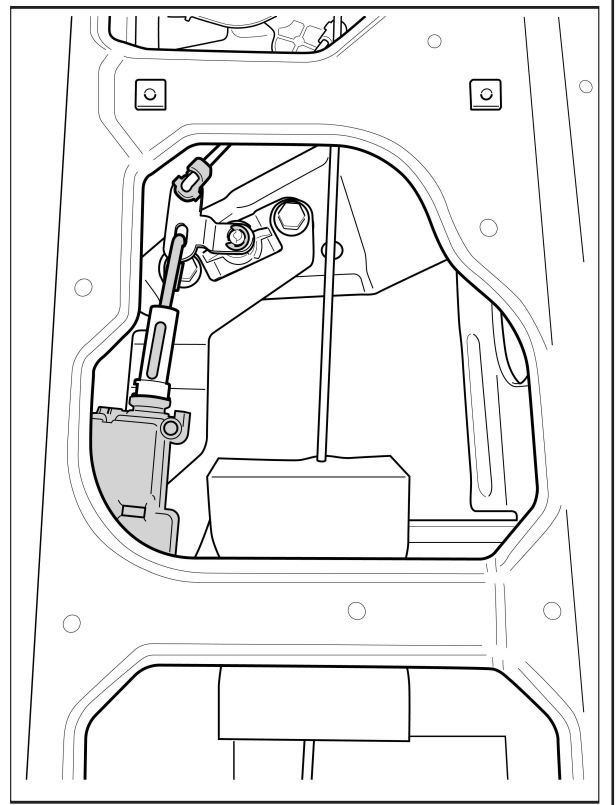

15

Re-fasten the tailgate cover.

