



# FITTING INSTRUCTIONS

Product: AIR COMPRESSOR/TANK BRACKET

Vehicle: NISSAN PATROL Y62

Part No. 076STACA13Y

- Before commencing fitment read instructions and ensure all listed components are supplied.
- Make sure to understand and abide by all safety regulations and instructions.
- Left hand & right-hand components are determined as seated in the vehicle.
- Always place the product on a soft workspace to prevent damage prior to installation.
- Note that due to the nature of these instructions covering several models, some images may be generic and not be of your specific vehicle.
- The fitment of TJM products does not nullify the OE manufacturer's operating guidelines and/or warnings. Ensure you are familiar with and adhere to the usage instructions specified by the manufacturer in the owner's manual or other official documentation.
- All fasteners installed must be inspected and torque checked.
- These instructions do not include any wiring details for the electrical components to be used with these products. Electrical system damage may be possible due to incorrect wiring or method and is the responsibility of the person fitting. Please consult an auto electrician if you are not comfortable with modifying the vehicles electrical system.
- These instructions do not include any details for fitment of the air fittings to be used with these products.
- Estimated fitting time of 2 hrs.

For product warranty please refer to our website [www.tjm.com.au](http://www.tjm.com.au)



# FITTING INSTRUCTIONS

Product: AIR COMPRESSOR/TANK BRACKET

Vehicle: NISSAN PATROL Y62

Part No. 076STACA13Y

STANDARD TORQUE SPECIFICATIONS						
All bolt torques are as follows unless otherwise specified by OEM or in these installation instructions	Dia. [mm]	Nm	lb. ft.	Dia. [inch]	Nm	lb. ft.
	6	12	9	5/16"	27	20
	8	31	23	3/8"	47	35
	10	61	45	7/16"	81	60
	12	102	75	1/2"	122	90
	14	163	120	9/16"	217	160
	16	224	165	5/8"	237	175

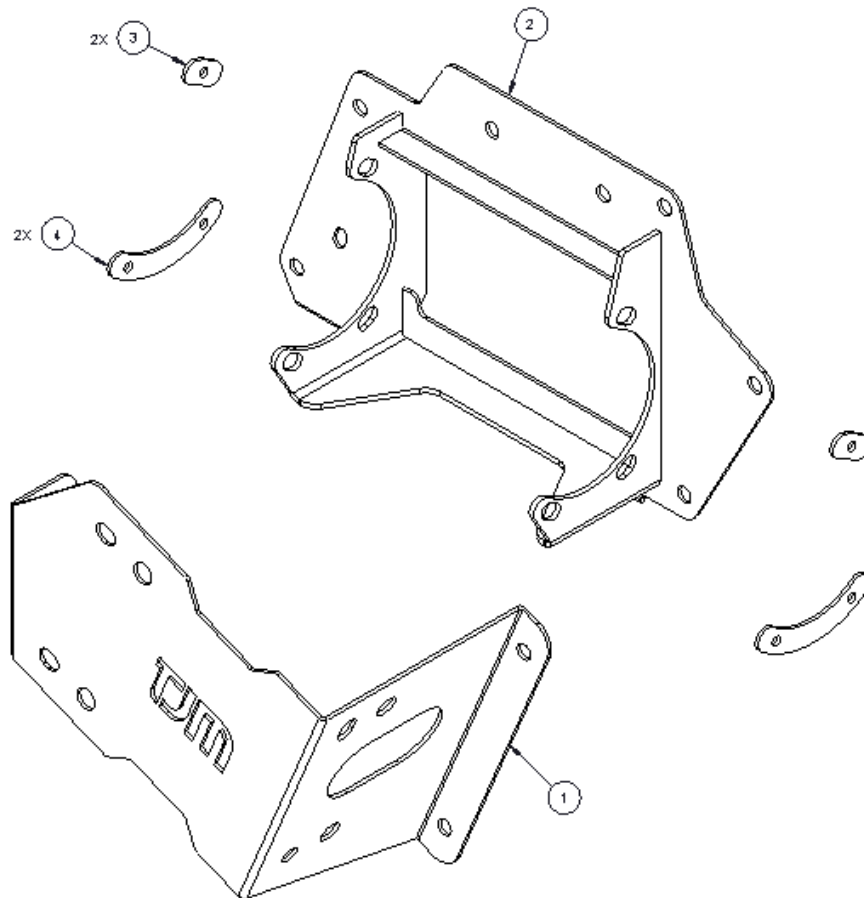

For product warranty please refer to our website [www.tjm.com.au](http://www.tjm.com.au)



# FITTING INSTRUCTIONS

Product: AIR COMPRESSOR/TANK BRACKET

Vehicle: NISSAN PATROL Y62

Part No. 076STACA13Y

Item No.	Part Description	Quantity	Part Number
1	Air Tank Bracket	1	F-32290
2	Air Compressor Bracket	1	F-32292
3	Compressor Mount Plate – Upper	2	F-33158
4	Compressor Mount Plate – Lower	2	F-33159
N/A	Fitting Instructions	1	F-34177
<b>Bolt Kit</b>			
N/A	M8 x 1.25 x 25mm Hex Head Screw	4	K0553
N/A	M8 x Ø19 - Ø22mm Flat Washer	8	K0628
N/A	M8 x 1.25 Nyloc Nut	4	K0606
N/A	M6 x 1.0 x 20mm Hex Head Screw	10	K0550
N/A	1/4 x Ø3/4 Flat Washer	15	K2905
N/A	M6 x 1.0 Nyloc Nut	5	K0605
N/A	M6 x 1.0 Flange Nut	2	K3033

For product warranty please refer to our website [www.tjm.com.au](http://www.tjm.com.au)



# FITTING INSTRUCTIONS

Product: AIR COMPRESSOR/TANK BRACKET

Vehicle: NISSAN PATROL Y62

Part No. 076STACA13Y

## INSTRUCTIONS TO ASSEMBLE AIR TANK

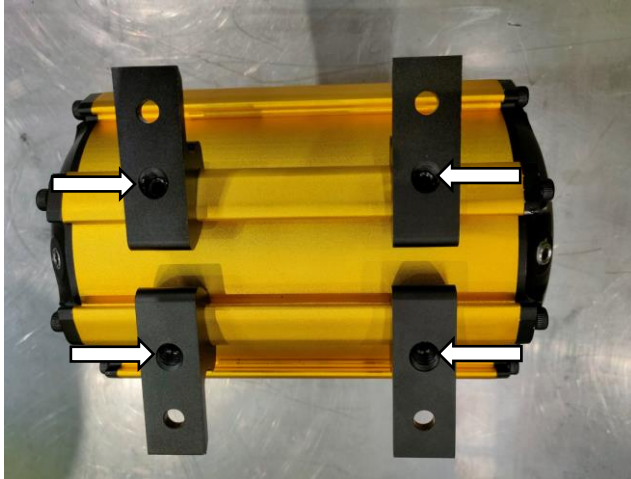

1. Loosen the indicated fasteners (4) to separate the Air Tank from the Mounting Feet (4).

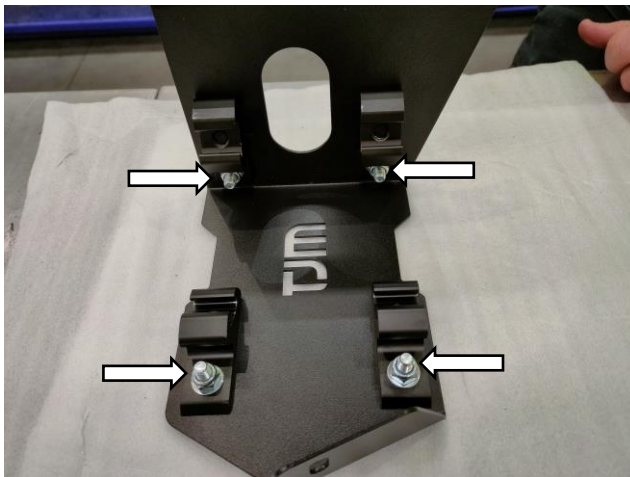

2. Loosely secure the Mounting Feet (4) on the supplied Air Tank Bracket using M8 x 1.25 x 25mm Hex Head Screws (4), Flat Washers M8 (8) and M8 x 1.25 Nyloc Nuts (4) as indicated.

**Note:** Fasteners should be orientated so that the Nyloc Nut is positioned on the Mounting Foot side of each joint.

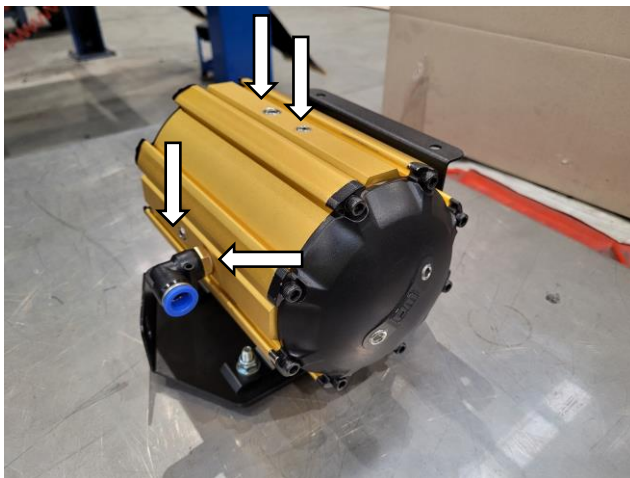

3. Insert the Tank in the Air Tank Bracket by sliding it through the loosely secured Mounting Feet.

**Note:** It is recommended to orientate the Tank with the side ports facing as indicated. This will allow the best access to both the side and end ports once installed in the vehicle.

For product warranty please refer to our website [www.tjm.com.au](http://www.tjm.com.au)



# FITTING INSTRUCTIONS

Product:	AIR COMPRESSOR/TANK BRACKET
Vehicle:	NISSAN PATROL Y62
Part No.	076STACA13Y

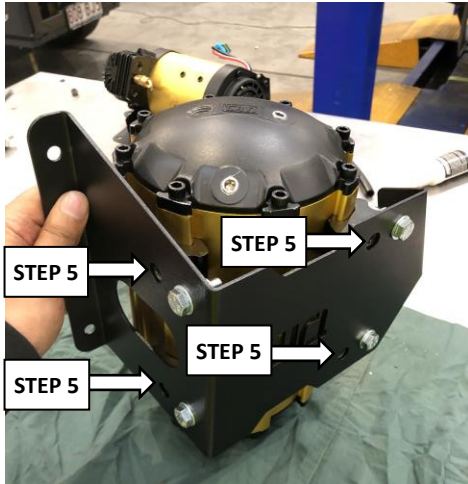

- Secure the M8 fasteners from step 2.
- Leave the fasteners indicated (4) slightly loose to allow the Tank to slide within the Air Tank Bracket. These fasteners will be tightened once the components are installed in the vehicle.

## INSTRUCTIONS TO ASSEMBLE AIR COMPRESSOR

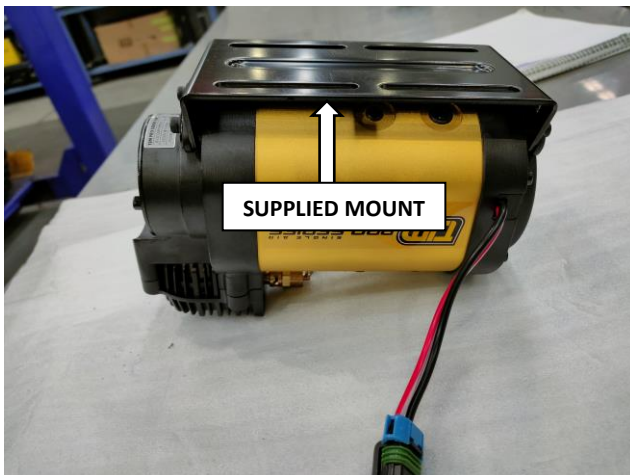

- Remove (& discard) the supplied Compressor Mounting Brackets. Retain only the fasteners (6), Rubber Isolation Mounts (6), and Brass Crush Tubes (6).

FAN SIDE SHOWN

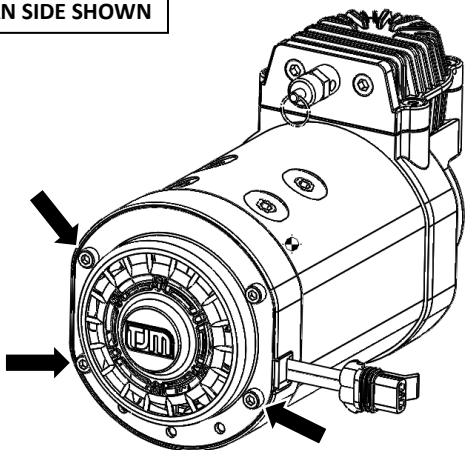

- Remove (& discard) indicated fasteners (3) from the fan side of the Compressor.

For product warranty please refer to our website [www.tjm.com.au](http://www.tjm.com.au)



# FITTING INSTRUCTIONS

Product:	AIR COMPRESSOR/TANK BRACKET
Vehicle:	NISSAN PATROL Y62
Part No.	076STACA13Y

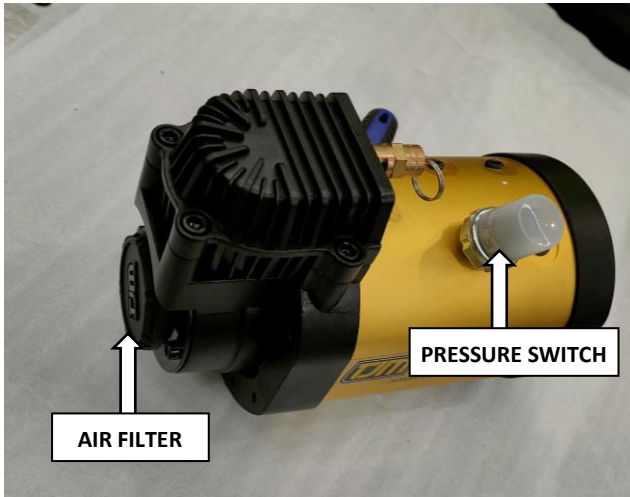

8. Secure Pressure Switch and Air Filter on the Compressor.

**Note:** Refer to the TJM Pro Series Single Air Compressor instruction manual for correct fitment of these components.

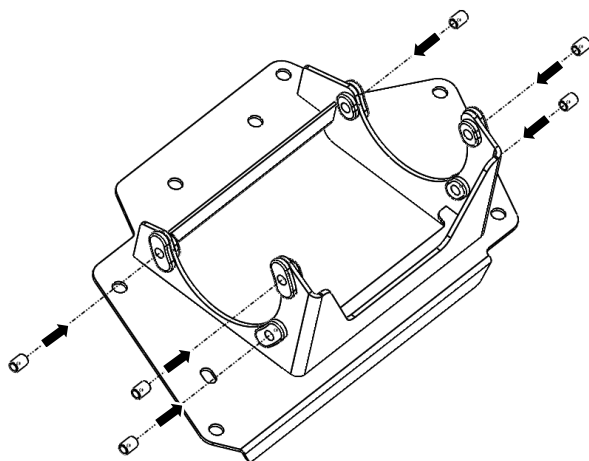

9. Secure Rubber Isolation Mounts (6) & Brass Crush Tubes (6) retained in step 6 on the Air Compressor Bracket as shown.

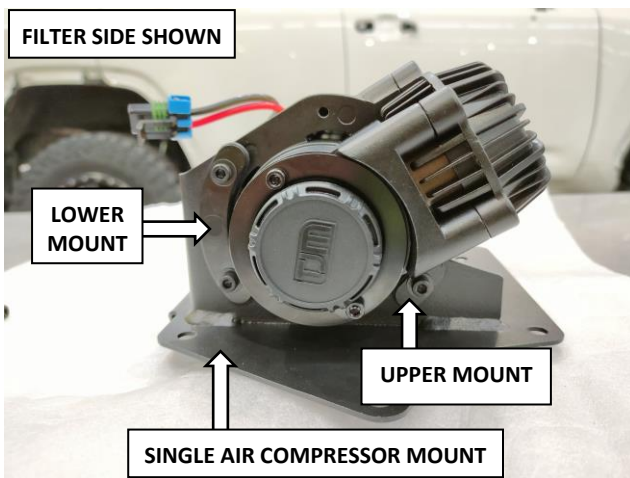

10. Secure the Compressor to the Air Compressor Bracket using the Compressor Mount Plates (Lower & Upper) and the retained fasteners (3) from step 6.



# FITTING INSTRUCTIONS

Product: AIR COMPRESSOR/TANK BRACKET

Vehicle: NISSAN PATROL Y62

Part No. 076STACA13Y

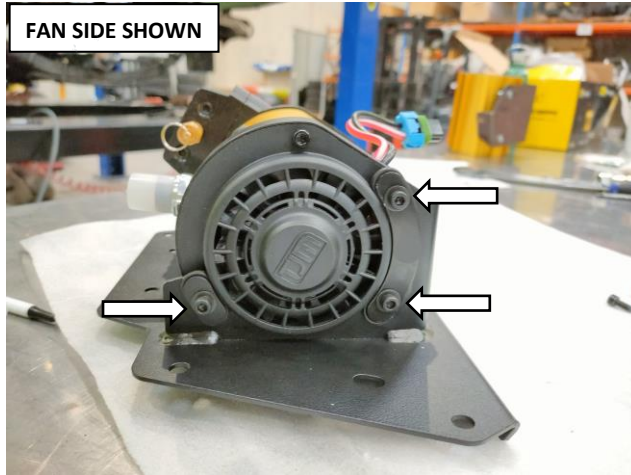

11. Repeat previous step on the fan side of the Compressor to fully secure it to the Air Compressor Bracket.

## INSTRUCTIONS TO REMOVE SIDE TRIM PANEL



12. Open the luggage compartment of the vehicle and clear the indicated space for Air Tank and Compressor installation.

**Note:** The components will be installed behind the LHS trim panel as indicated.

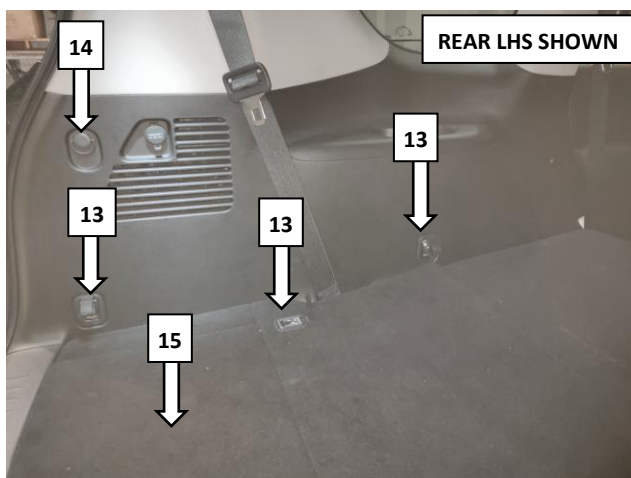

13. Remove (& retain) the luggage tie down points (3).

14. Remove (& retain) the luggage hook (1).

15. Lift the rear most boot floor panel.

For product warranty please refer to our website [www.tjm.com.au](http://www.tjm.com.au)



# FITTING INSTRUCTIONS

Product:	AIR COMPRESSOR/TANK BRACKET
Vehicle:	NISSAN PATROL Y62
Part No.	076STACA13Y

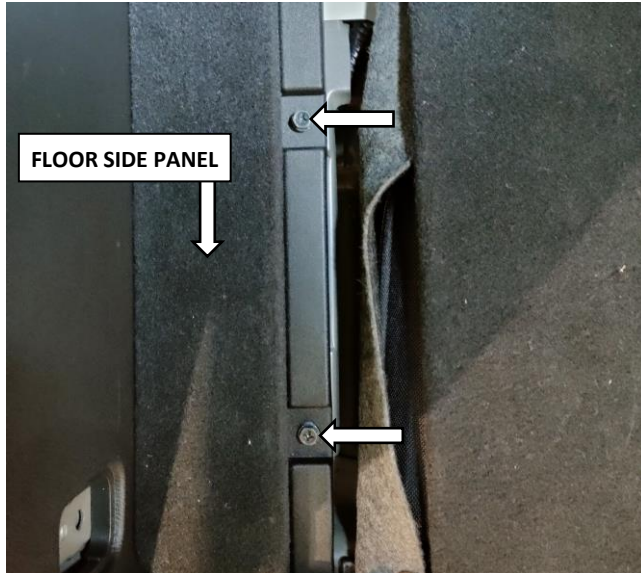

16. Remove (& retain) the indicated fasteners (2) and unclip the floor side panel.



17. Lift and unclip the luggage floor panel as shown.

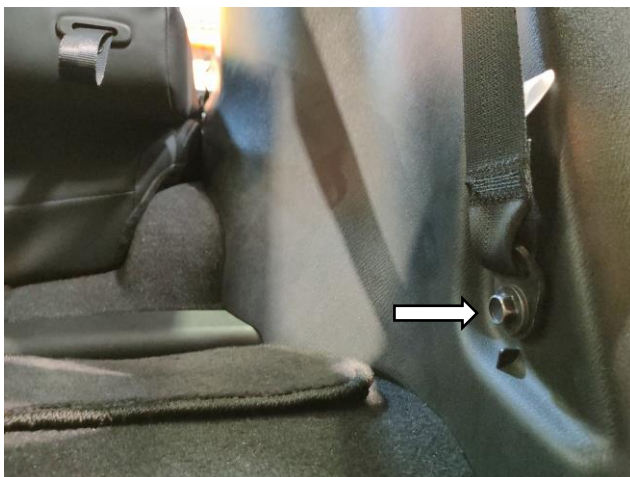

18. Remove (& retain) the indicated fastener from the 3<sup>rd</sup> row lower seat belt mount.

For product warranty please refer to our website [www.tjm.com.au](http://www.tjm.com.au)





# FITTING INSTRUCTIONS

Product:	AIR COMPRESSOR/TANK BRACKET
Vehicle:	NISSAN PATROL Y62
Part No.	076STACA13Y



19. Open the passenger side rear door and remove (& retain) the indicated fastener from the 2nd row lower seat belt mount.

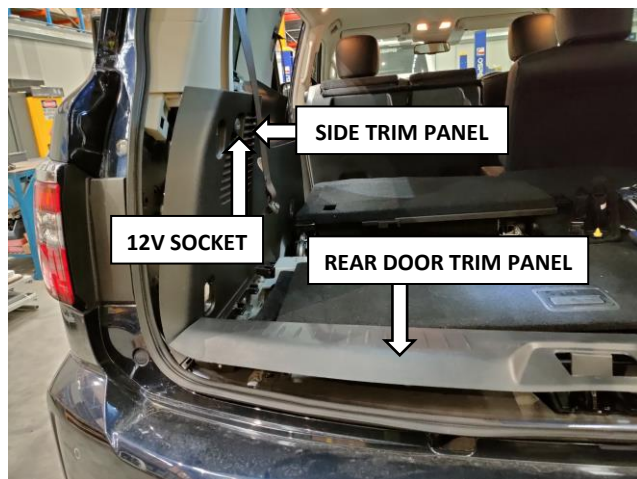

20. Partially unclip the side trim panel.

**Note:** Carefully remove the electrical connector from the 12V accessory socket located on the rear side of the side trim panel.

21. Fully remove the two panels illustrated from the vehicle.

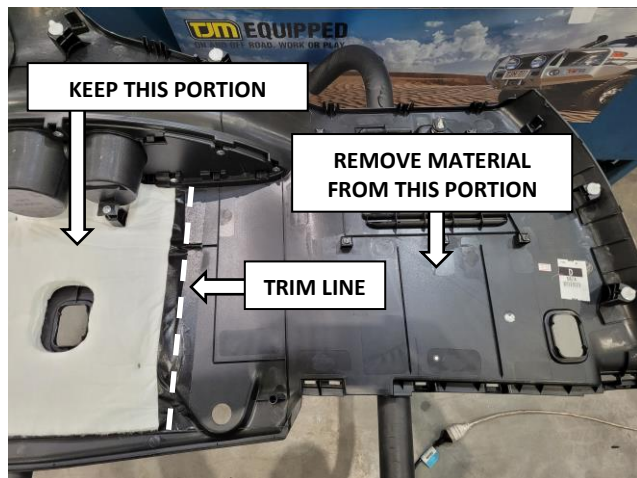

22. Trim the sound deadening material from the rear of the side trim panel as shown.

23. Tape the edge of the material to ensure there are no loose fibres.

For product warranty please refer to our website [www.tjm.com.au](http://www.tjm.com.au)



# FITTING INSTRUCTIONS

Product:	AIR COMPRESSOR/TANK BRACKET
Vehicle:	NISSAN PATROL Y62
Part No.	076STACA13Y

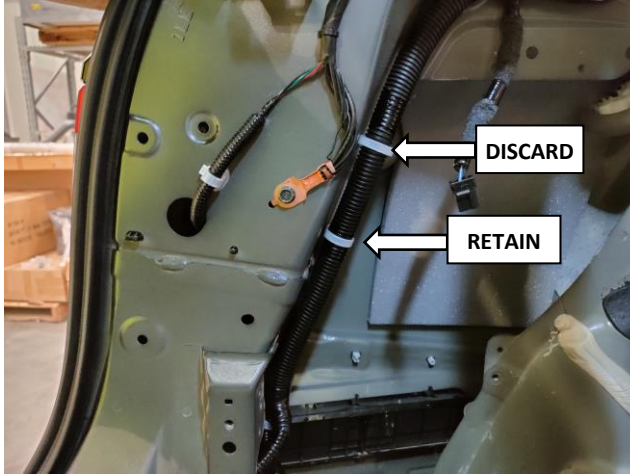

- 24. Unclip (& discard) the upper cable tie mount.
- 25. Unclip (& retain) the lower cable tie mount.

## INSTRUCTIONS TO INSTALL AIR COMPRESSOR & TANK BRACKETS

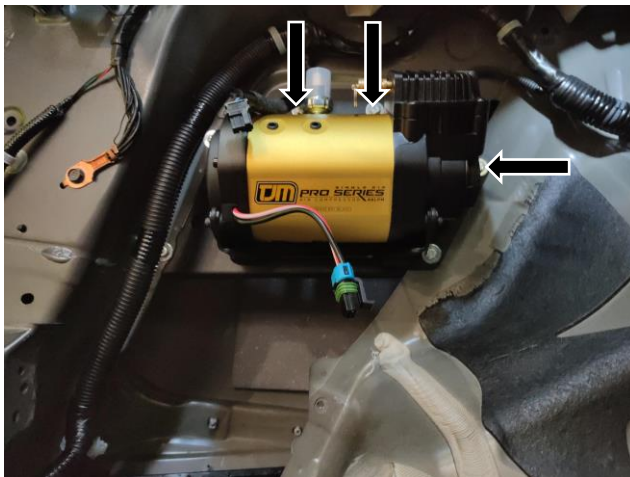

**Note:** It is recommended to install the required air fittings and hose prior to securing the Air Compressor Bracket to the vehicle.

- 26. Loosely secure the Air Compressor Bracket to the vehicle captive nuts (3) indicated, using M6 x 1.0 x 20mm Hex Head Screws (3) and 1/4 x Ø3/4 Flat Washers (3).

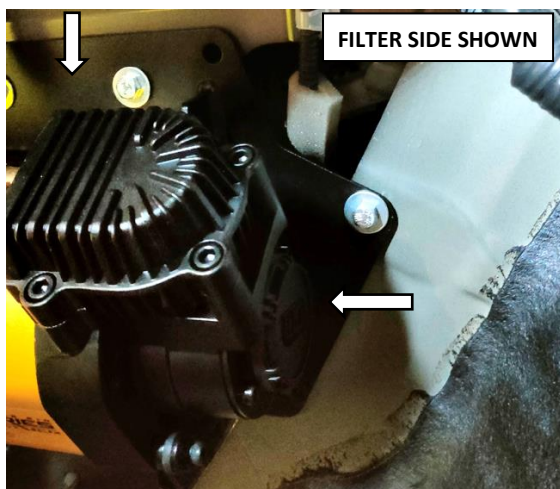

**Note:** The upper and filter side of the Air Compressor Bracket will be positioned in front of the body panels as shown.

For product warranty please refer to our website [www.tjm.com.au](http://www.tjm.com.au)



# FITTING INSTRUCTIONS

Product: AIR COMPRESSOR/TANK BRACKET

Vehicle: NISSAN PATROL Y62

Part No. 076STACA13Y

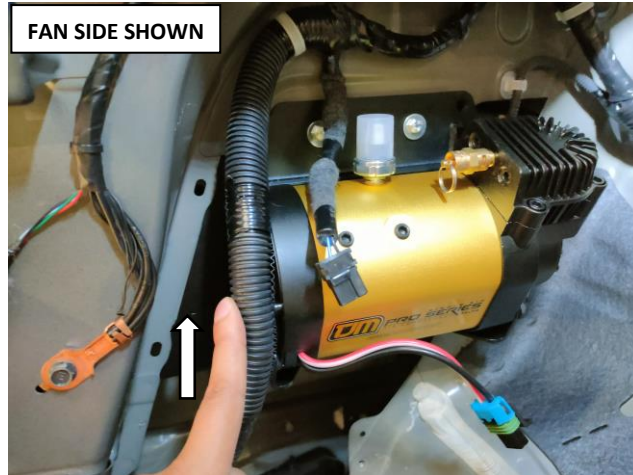

**Note:** Ensure the fan side of the Air Compressor Bracket is positioned behind the body panels as shown.

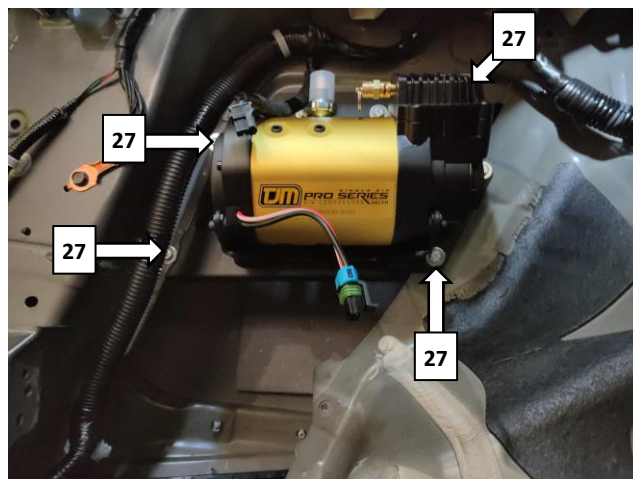

27. Secure the Air Compressor Bracket using supplied M6 x 1.0 x 20mm Hex Head Screws (4), 1/4 x Ø3/4 Flat Washers (8) and M6 x 1.0 Nyloc Nuts (4).

28. Secure the fixings (3) from step 26.

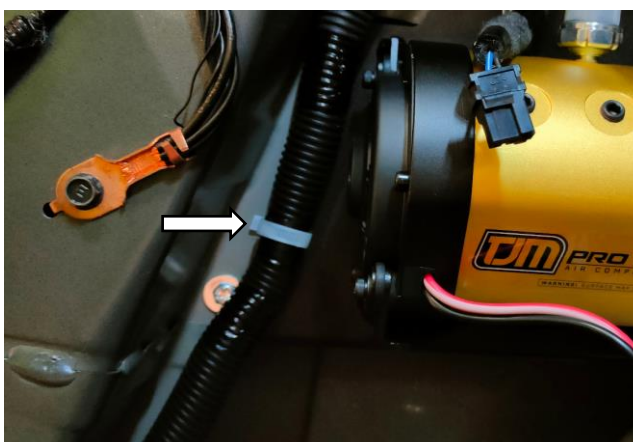

29. Secure the OE electrical harness to the Air Compressor Bracket using the retained cable tie mount as shown.

For product warranty please refer to our website [www.tjm.com.au](http://www.tjm.com.au)



# FITTING INSTRUCTIONS

Product: AIR COMPRESSOR/TANK BRACKET

Vehicle: NISSAN PATROL Y62

Part No. 076STACA13Y

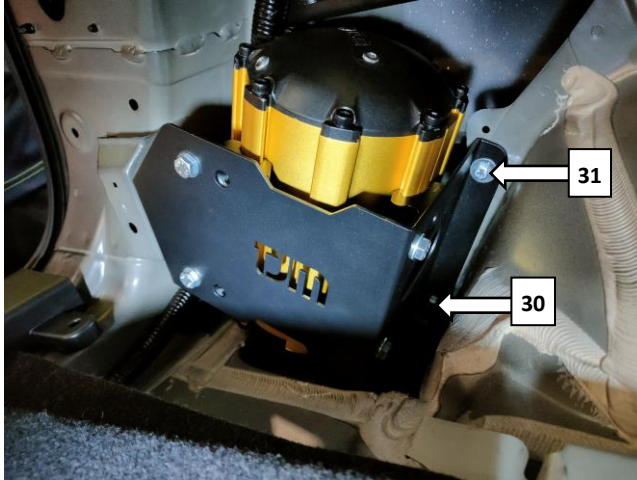

**Note:** It is recommended to install the required air fittings prior to securing the air tank to the vehicle.

30. Secure Air Tank Bracket using M6 x 1.0 x 20mm Hex Head Screw, 1/4 x Ø3/4 Flat Washer and M6 x 1.0 Flange Nut at indicated location.

31. Secure the Air Tank Bracket using M6 x 1.0 x 20mm Hex Head Screw, 1/4 x Ø3/4 Flat Washers (2) and M6 x 1.0 Nyloc Nut.

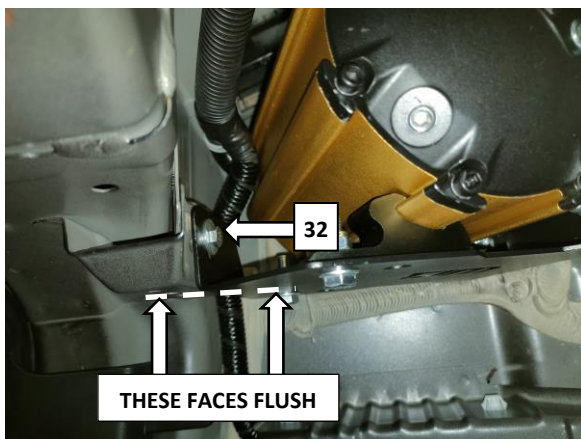

32. Secure Air Tank Bracket using M6 x 1.0 x 20mm Hex Head Screw, 1/4 x Ø3/4 Flat Washer and M6 x 1.0 Flange Nut at indicated location.

**Note:** Ensure the Air Tank Bracket sits flush with the body panel as shown before tightening.

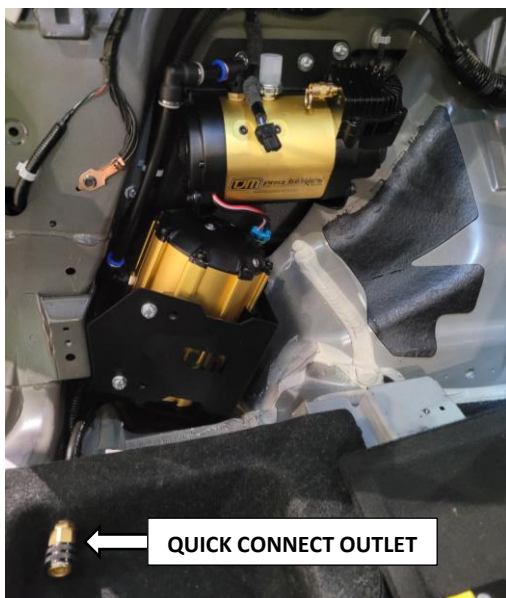

33. Position the Tank as required by sliding it within the Air Tank Bracket. Tighten the fasteners from step 5 ensuring the Tank has sufficient clearance to any body panels, electrical cables and air fittings.

34. Electrical wiring can now be fitted. Refer to the TJM Pro Series Single Air Compressor instruction manual for guidance as required.

**Note:** Air fittings and hose (including the quick connect bulkhead outlet) are not supplied. These are available to purchase separately to this mounting kit.

For product warranty please refer to our website [www.tjm.com.au](http://www.tjm.com.au)



# FITTING INSTRUCTIONS

Product: AIR COMPRESSOR/TANK BRACKET

Vehicle: NISSAN PATROL Y62

Part No. 076STACA13Y

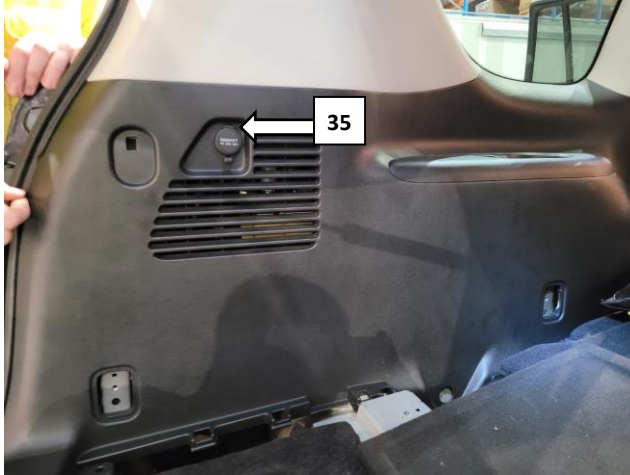

35. Re-connect the 12V accessory socket and then re-install the side trim panel.

36. Refit the OE components in the luggage compartment by following the reverse of installation steps above.

**Installation Complete – Take the Lead!**

For product warranty please refer to our website [www.tjm.com.au](http://www.tjm.com.au)